

SWD Transfer Case for BRX02-88 (#)

Difficulty Level: ★★★★★

INSTALLATION MANUAL

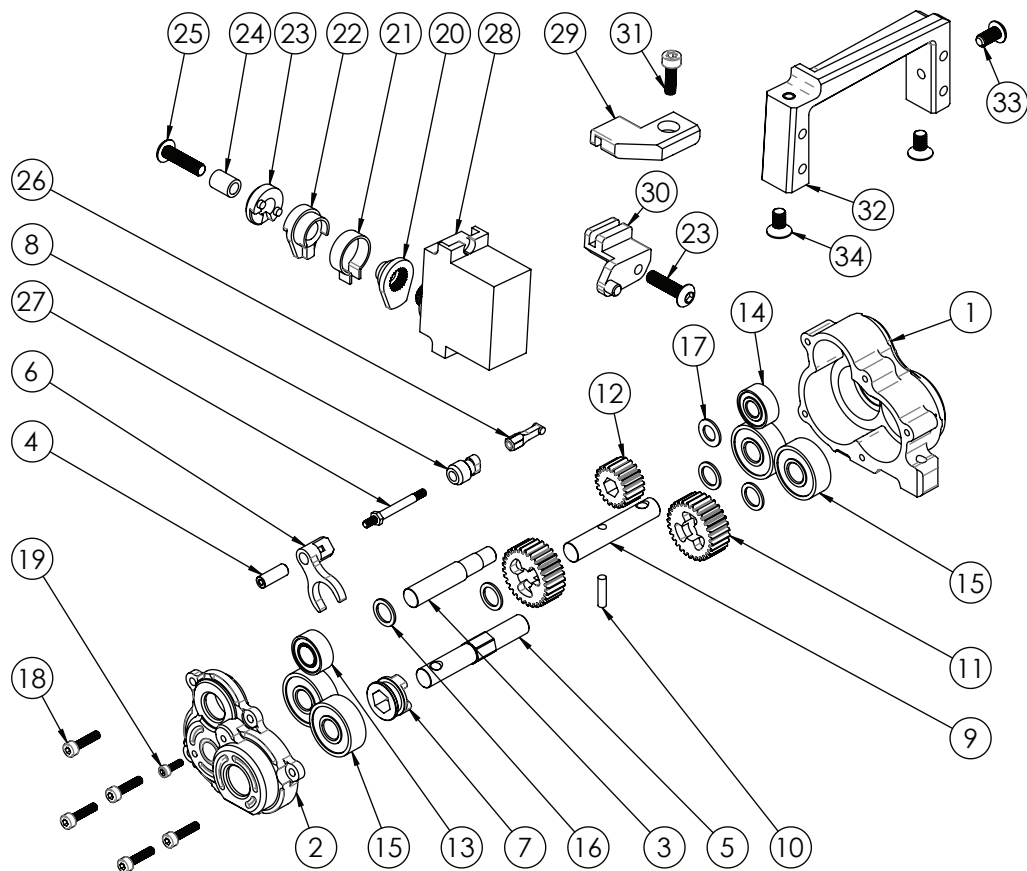

Parts Included:	Qty.
(1) T-Case Housing	1
(2) T-Case Cover	1
(3) Guiding Shaft	1
(4) Guide	1
(5) Front Output Shaft #BRLC70301-B	1
(6) Shift Fork	1
(7) Catcher	1
(8) Shift Rod Bushing	1
(9) Rear Output Shaft #BRLC7208	1
(10) D2 x 8 pin #BRSSPIN2008	1
(11) 29T Spur Gear	2
(12) 20T Input Gear #BRLC70210	1
(13) D5 x 10 x 4 Bearing #BBZMR1052RS	1

Parts Included:	Qty.
(14) D4 x 10 x 4 Bearing	4
(15) D5 x 14 x 5 Bearing #BBZMR1042RS	4
(16) D5 x 7 x 0.5 Spacer	4
(17) D4 x 7 x 0.5 Spacer	1
(18) M2 x 8 SC Screw #BRPROB-07	5
(19) M1.6 x 5 SC Screw #BRASCH1605	1
(20) Horn Initiator	1
(21) Tension Spring	1
(22) Horn Follower	1
(23) Follower Cap	1
(24) Follower Pivot Spacer	1
(25) M3 x 12 RC Screw #BRASBH3012	2
(26) T-Shape Grip	1

Parts Included:	Qty.
(27) Shift Rod	1
(28) JX Water Proof Servo #JX/PDI-HV1151MG	1
(29) Servo Top Bracket	1
(30) Servo Bottom Bracket #BRASCH2508	1
(31) M2.5 x 8 SC Screw #BRASBH3006	1
(32) Winch Mount #BRASBH3006	1
(33) M3 x 6 RS Screw #BRASFH3006	2
(34) M3 x 6 CSS Screw #BRASFH3006	2
(35) 16T Spur Gear	1
(36) 33T Spur Gear	1
(37) 25T Spur Gear #BRLC70201-GEAR	1

T-Case Cover

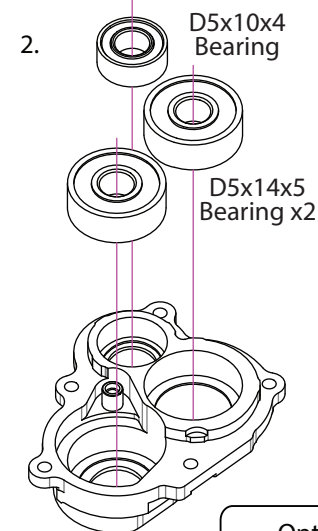
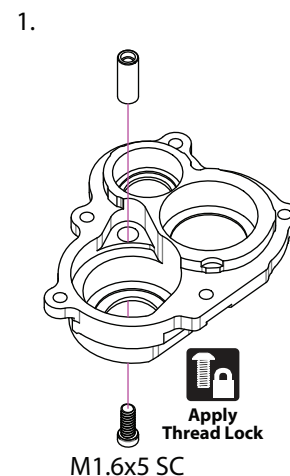

T-Case Housing

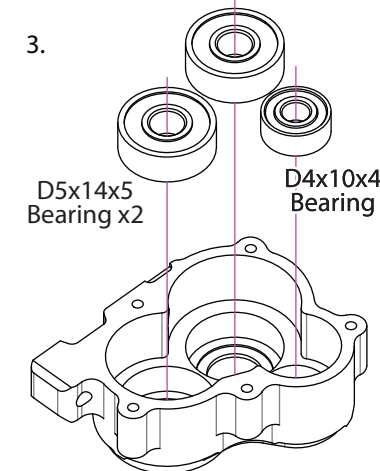

Optional overdrive gears set

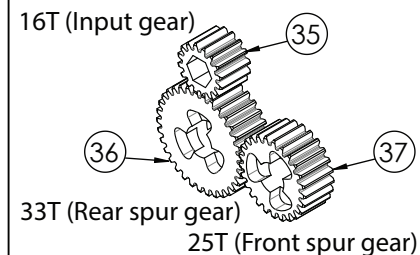

4. Apply black grease on both spacers for sticking onto the input gear.

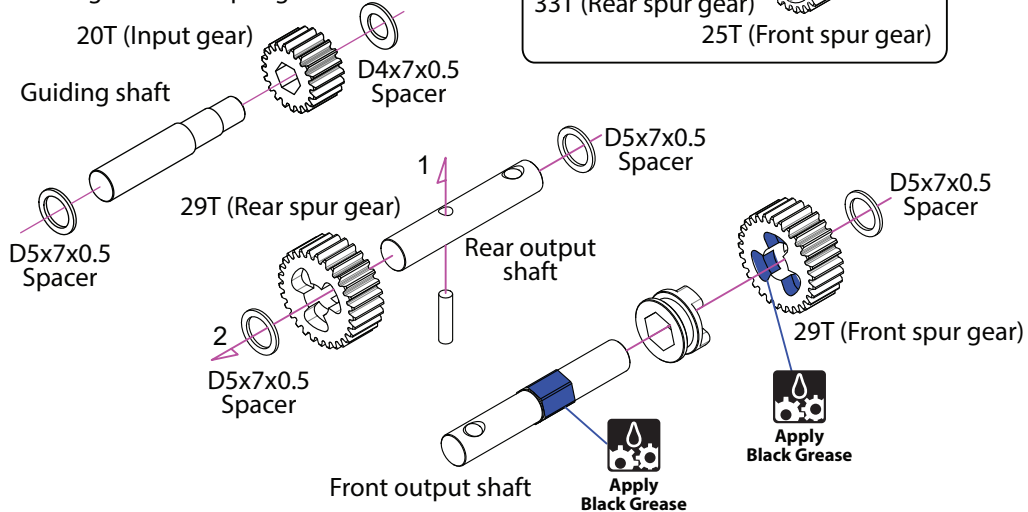

SWD Transfer Case for BRX02-88 (#)

Difficulty Level: ★★★★★

5.

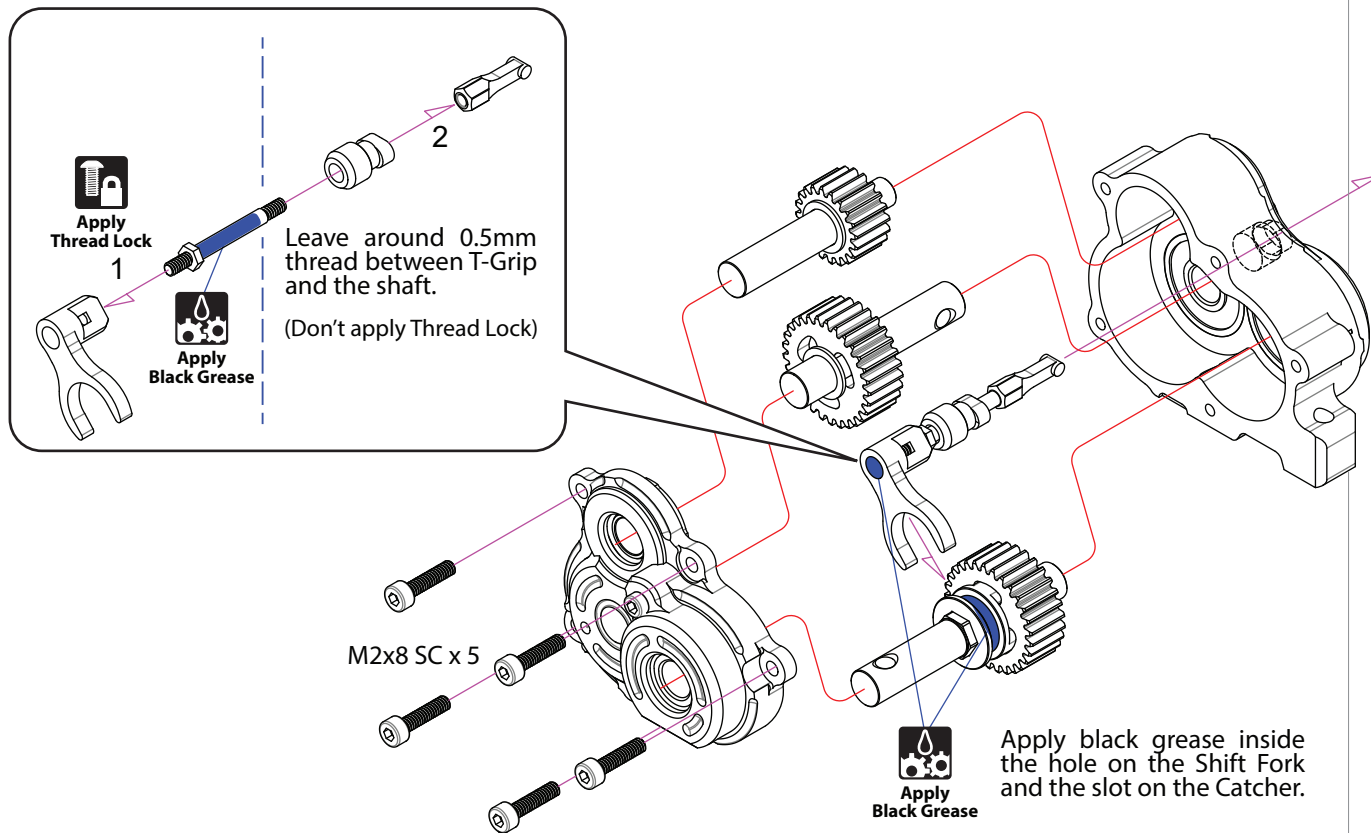

6.

Turn the Shift Rod Bushing clockwise to lock.

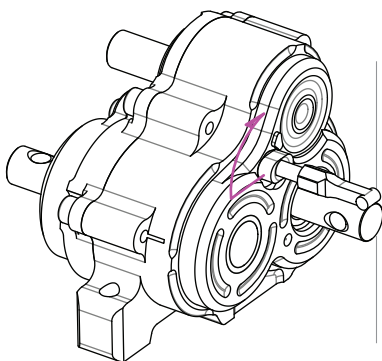

7.

Adjust the T-Grip clockwise to make the handle position horizontally.

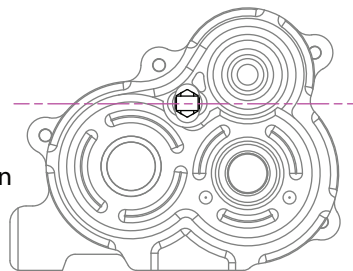

8.

If the transmission on the chassis has been previously installed, detach the drive shafts and remove both the gearbox and the transfer case from the chassis.

Carefully remove the Guiding Shaft(*) in an upward direction to prevent misalignment between the spacers and the input gear inside the transfer case before engaging the new transfer case with the gearbox. Then proceed to re-install the unit onto the chassis.

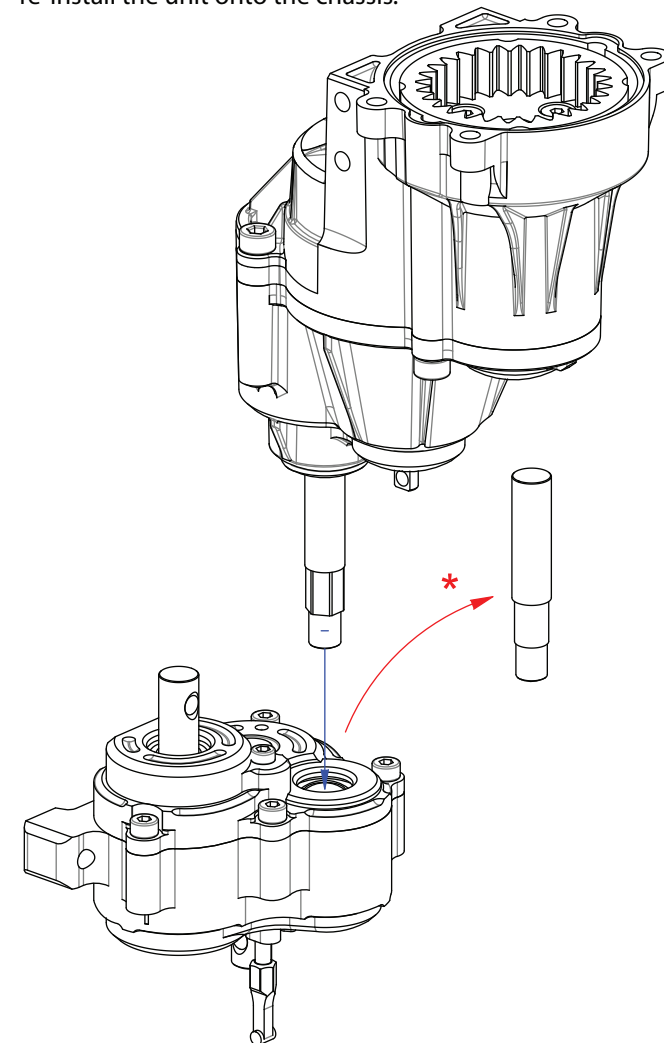

SWD Transfer Case for BRX02-88 (#)

Difficulty Level: ★★★★★

9.

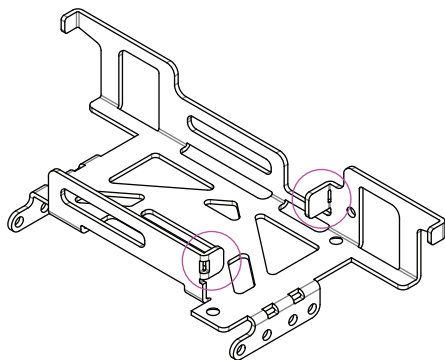

If the winch mount is not installed previously, detach the battery tray and bend inward both tabs indicated.

10.

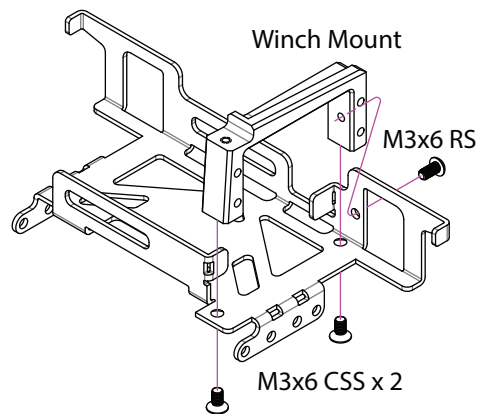

11.

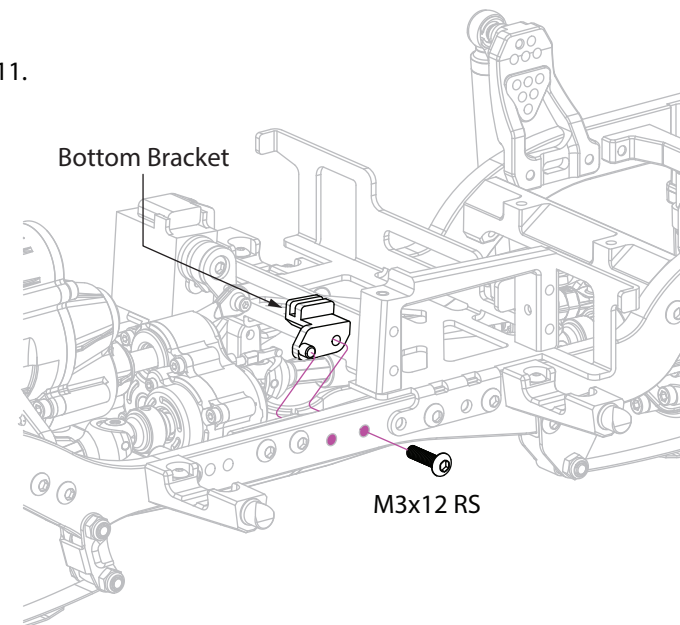

12.

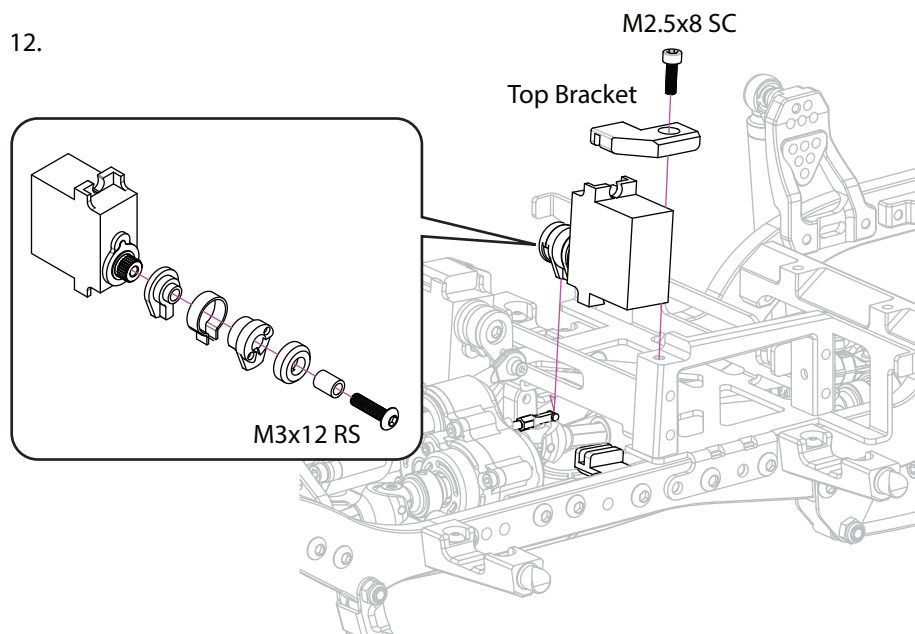

13.

