

SCALE **4WD** Series

BOLT-ON KIT
PARTIAL ASSEMBLY REQUIRED

BOOMRACING 

BRX01

AWB

ADJUSTABLE WHEELBASE 1/10 4WD RADIO CONTROL CHASSIS KIT

LINK VERSION

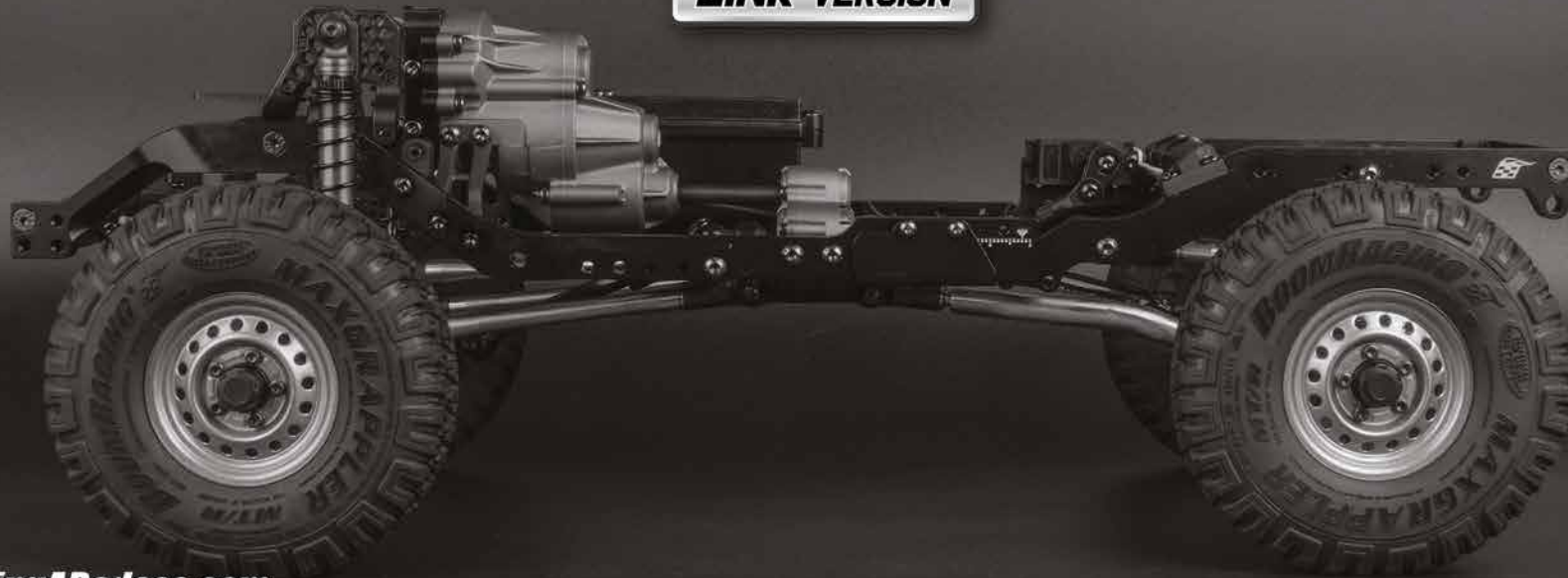

www.EnjoyBeingABadass.com

Product Codes:
Full Kit w/ Zil Pickup Body - BR8013
Builder's Kit - BR8014
INSTRUCTION MANUAL
VERSION 1.1

Photo for reference only.

BUILT TO ADAPT, ENGINEERED TO PERFORM

Welcome to the Boom Racing Family!

Congratulations on your new BRX01 AWB LINK chassis! You now own a truly extraordinary platform, engineered for adaptability and high performance.

Your Unique Vehicle Identity

Every BRX01 AWB comes with a customized chassis plate and a pair of unique license plates. The chassis plate includes your Vehicle Identification Number (VIN #) and vehicle number, which matches the license plates. Use both numbers to register your chassis and unlock exclusive benefits.

Why Register?

By registering, you'll get access to:

- ✓ Vehicle history and details
- ✓ Factory warranty and replacement parts
- ✓ Exclusive event promotions at Boom Racing events
- ✓ Mileage tracking through Scaletra app

How to Register?

1. Visit BoomRacing.com > Vehicle Registration
2. Log in or create an account.
3. Fill out the vehicle registration form. In the chassis detail section, select the car model BRX01 AWB, and use the vehicle number and VIN number found on the chassis plate.
4. Submit the form. If the details are correct, your vehicle will be registered immediately.

Track Your Adventures with Scaletra

We're excited to partner with **Scaletra Adventure**, the RC tracking app for scale trail enthusiasts. Scaletra lets you log your trail runs, build your virtual RC garage, join challenges, and connect with the community, and more!

As a BRX vehicle owner, you get exclusive benefits:

- Automatically sync your registered vehicles from your Boom Racing account to Scaletra.
- Register new BRX vehicles directly on Scaletra — they'll sync back to your Boom Racing account.
- Add an unlimited number of BRX vehicles to your Scaletra garage.
- Vehicle mileage syncs back to your Boom Racing account.

Thank you for choosing Boom Racing. Now, get out there and commit some badassery!

CHASSIS PLATE



Scan to register your BRX01 AWB



LICENSE PLATE



FRONT AND REAR

LINK



A Bolt-On Kit means parts of the chassis are pre-assembled and require minor assembly for completion. The factory assembled parts offer convenience for builders eager to get started. The BRX01 AWB kit includes factory pre-built axles, transmission, transfer case and shocks. Shocks require oil to be filled (included).



The Scale 4WD Series is Boom Racing's line of scale based 4WD R/C products geared towards realistic appearance.



⚠ NOT RECOMMENDED FOR CHILDREN UNDER 14 ⚠

THIS CHASSIS KIT IS NOT A TOY. FIRST-TIME BUILDERS SHOULD SEEK ADVICE FROM PEOPLE HAVING BUILDING EXPERIENCE IN ORDER TO ASSEMBLE THE MODEL CORRECTLY. ASSEMBLE THIS KIT ONLY IN PLACES OUT OF CHILDREN'S REACH.



BEFORE YOU PROCEED

Congratulations! Owning the BRX01 AWB is a truly special experience.

Carefully read and follow all instructions to prevent serious damage to your model. Failure to follow these instructions will be considered abuse and/or neglect.

Study the instructions thoroughly before assembly.

There are many small screws, nuts and similar parts. Assemble them carefully referring to the drawings. Follow the steps exactly as shown to build the vehicle correctly without issues.

If you decide to return the BRX01 AWB, do not begin assembly. Your hobby dealer will not accept a model for return or exchange after you have started assembly.

Boom Racing offers Spare Parts & Upgrade Options for improved performance. Visit our website (<https://www.enjoybeingabadass.com>) or your local Boom Racing dealer for assistance. Please note that specifications, availability and price are subject to change without notice.

SAFETY PRECAUTIONS

All of us here at Boom Racing want you to enjoy your new vehicle. Operate your BRX01-AWB sensibly and with care, and it will be exciting, safe and fun for you and those around you. Failure to operate your BRX01 AWB in a safe and responsible manner may cause damage and injury and void your warranty.

Follow these outlined rules for safe radio control operation

- Read carefully and fully understand the instructions before assembly.
- ***This model is not intended for use by children (minors) under 14 years of age without the supervision of a responsible and knowledgeable adult who should also read the instructions.***
- When assembling this kit, extra care should be taken to avoid personal injury. Keep out of reach of small children.
- Avoid running the vehicle in crowded areas and near small children.
- BRX01 AWB can be very fast and quiet. It could cause injury to those unaware of its presence.

Inspect Your BRX01 AWB Before and After Operation

- Make sure that all screws and nuts are properly tightened.
- Use thread lock on screws for any metal on metal surface.
- Adjust steering servo and trim so that the BRX01 AWB runs straight with transmitter in neutral.
- Disconnect/remove all batteries after operation.
- Replace any batteries that have been dented, are bloated, or have frayed wires, short circuits can cause fire.
- Completely remove sand, mud, dirt etc after use to prolong the life of the BRX01 AWB.
- Maintain bearings by cleaning or replacing them regularly.

WARRANTY

Boom Racing's One (1) Year Factory Limited Warranty – A Peace Of Mind Right From The Start

WHO IS COVERED

This warranty is extended to the original end-user that registers it online (<https://www.boomracing.com/vehicleregistration>) only, whether purchased or received as a gift.

FACTORY LIMITED WARRANTY

What Is Covered and For How Long

Boom Racing warrants that all new products are free from defects in manufacturing, materials and workmanship for a period of one (1) year from date of retail purchase. The receipt or invoice at the time of purchase is your proof of purchase and is required for Boom Racing to honor any warranty.

What Is Not Covered

It does not cover defects or malfunction caused by user error of assembly, damages due to normal wear and tear, failure to follow operating instructions, misuse or abuse, users' failure to perform routine maintenance, or use with products with which is not intended to be used. It also does not cover damages caused by unauthorized alteration, modification or repair. It does not cover cosmetic or incidental damages. Boom Racing does not warrant or provide service or support for any third party products.

The JX mini servo warranty will be void if it is disassembled.

What We Will Do

We will, at our discretion, repair or replace any product free of charge that is incorrectly made or proves to be defective in material or workmanship during the warranty period. If your product is no longer being manufactured or is out of stock, we may replace your product with a comparable or improved product at our option.

What We Will Not Do

We will not pay for shipping, insurance or transportation charges from you to us, or any import fees, duties and taxes.

What To Do To Obtain Warranty Service

To obtain warranty service for products purchased from a third-party, retail or directly from Boom Racing you must return the product with proof of purchase using the following procedures:

1. Contact Boom Racing Customer Support for specific warranty instructions via our website, by email, telephone, or our social media accounts:

- Online @: <https://www.boomracing.com/contact-us>
- Email: sales@boomracing.com
- Facebook Messenger: (www.fb.com/boomracingrc) or Instagram: DM @boom_racing

You may be asked to complete a warranty service request form. A copy of your purchase receipt may be required.

2. Our Customer Support may ask you to return and ship the defective product back to us. Label and ship the product, freight prepaid, to the address provided by Boom Racing; and
3. Place any necessary return authorization number prominently on the outside of the return packaging. Return packaging not bearing a return authorization number where required may be refused.

Boom Racing reserves the right to final decision, change or modify this warranty without notice.

Equipment Required



3CH Radio

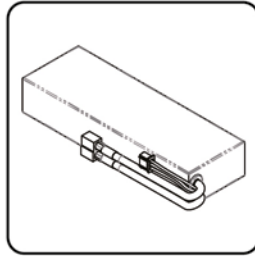

Battery

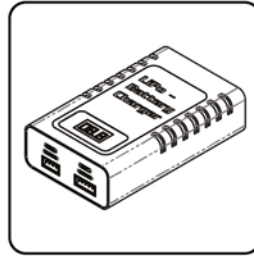

Charger

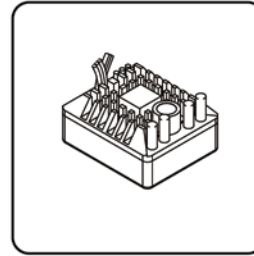

ESC

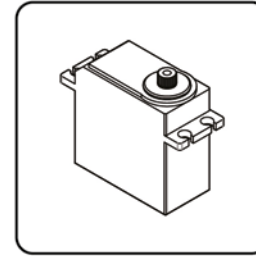

Steering Servo

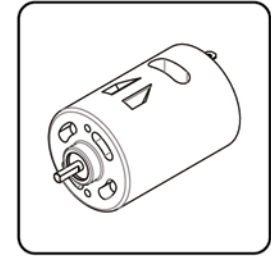

540/550 Motor

Tools Recommended

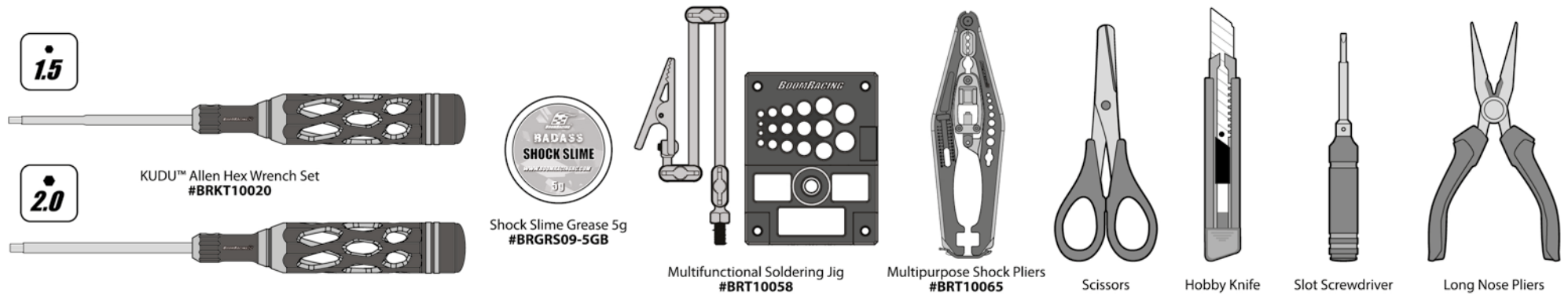

1.5

KUDU™ Allen Hex Wrench Set
#BRKT10020

2.0



Shock Slime Grease 5g
#BGRS09-5GB

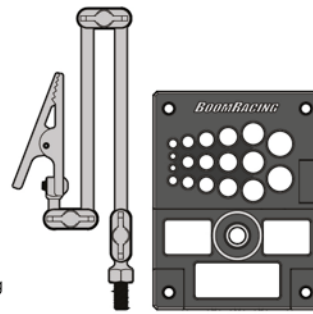

Multifunctional Soldering Jig
#BRT10058

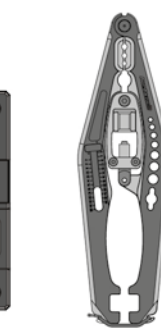

Multipurpose Shock Pliers
#BRT10065

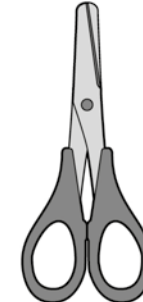

Scissors



Hobby Knife



Slot Screwdriver

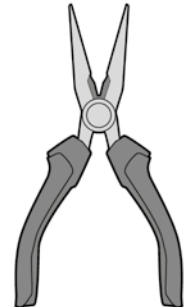

Long Nose Pliers

Icon Legend

These icons indicate safety warnings, required materials, and build tips used throughout this manual.



Thread Lock
Apply thread lock to places shown by this mark.
Apply thread lock first, then assemble.
(Do Not Use Red Loctite)



Black Graphite Grease
Lubricate all gears.
Apply grease to the places shown by this mark.
Apply grease first, then assemble.



Silicone Grease
Lubricate all moving parts including joints and bearings.
Apply grease to the places shown by this mark.
Apply grease first, then assemble.



Shock Oil
Apply shock oil to the places shown by this mark.



Apply Double Side Tape



Oil Leak Resistant



Item not included.



Pay attention to note on page.

PART LOCATION MAP (TOP)

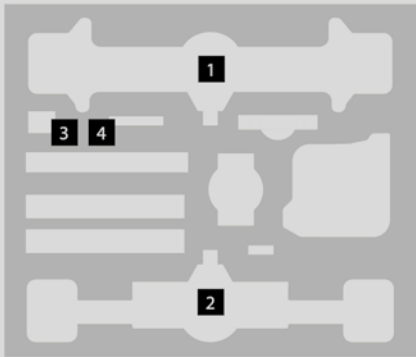

1

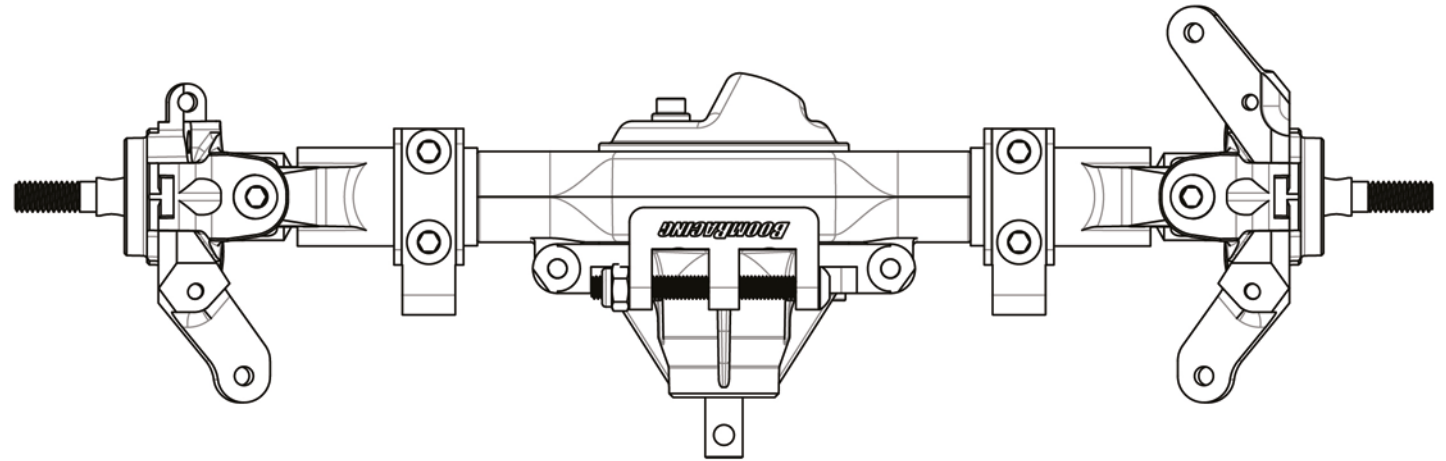

BRX80 Complete Front PHAT™ Axle Link Version Black
BRX020115LK

2

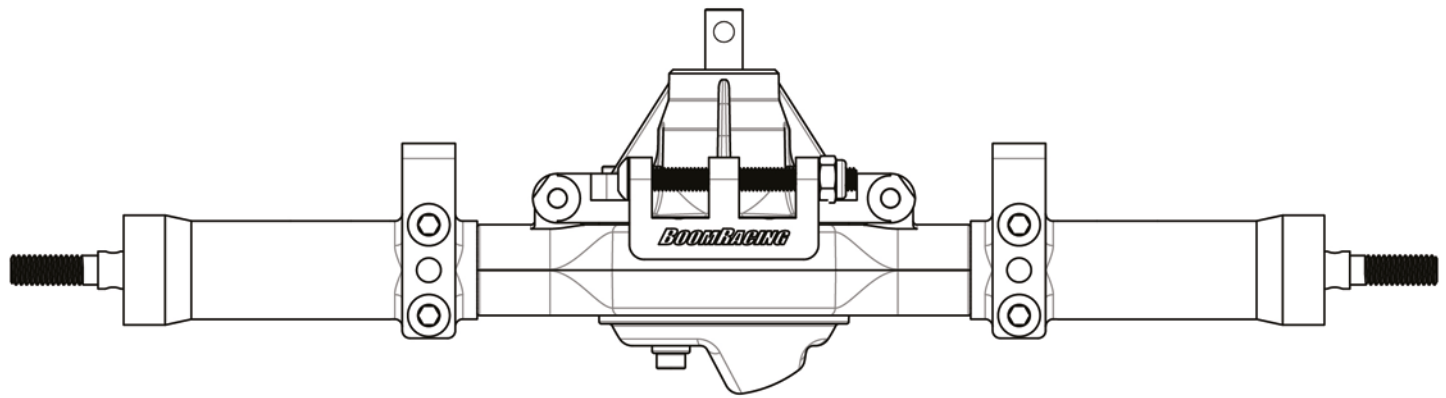

BRX80 Complete Rear PHAT™ Axle Link Version Black
BRX020115LKR

3

#BRX020110

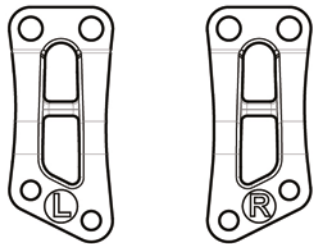

Side Gearbox Mount - Left x 1 Side Gearbox Mount - Right x 1

4

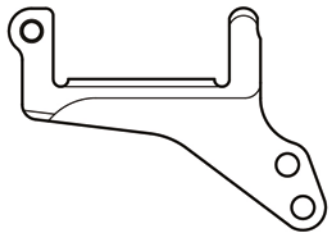

Mini Servo Mount for AWB x 1
#BRLC70223R

PART LOCATION MAP (TOP)

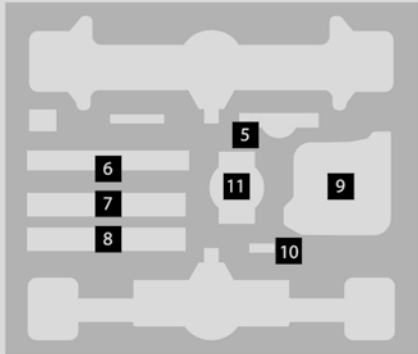

5 #BRLC7027V2

Gearbox Adapter x 1 Motor Mount x 1

6

KUDU™ 70mm Medium (Green) Coilover Scale Shock Absorber x 2
#BRSH0070-SP

7

KUDU™ 80mm Medium (Green) Coilover Scale Shock Absorber x 2
#BRSH0080-SP

9 #BRX020029

BCF2™ Aluminum Gearbox Housing x 1

8

KUDU™ Heavy-Duty 80-90mm Steel CVD Center Drive Shaft x 1
#BRKD003-90

KUDU™ Heavy-Duty 84-99mm Steel CVD Center Drive Shaft x 1
#BRKD003-94

10

Low Profile Servo Horn 25T Black x 1
#BR955014BK

11 #BRX020111

B2X™ Transfer Case Housing (OD Ready) x 1

PART LOCATION MAP (TOP)

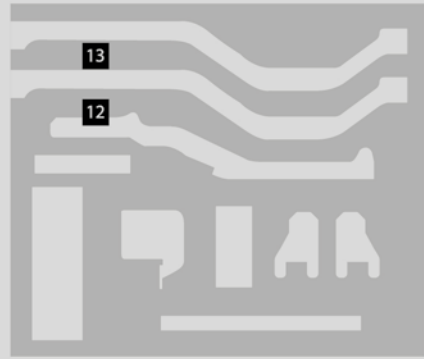

12

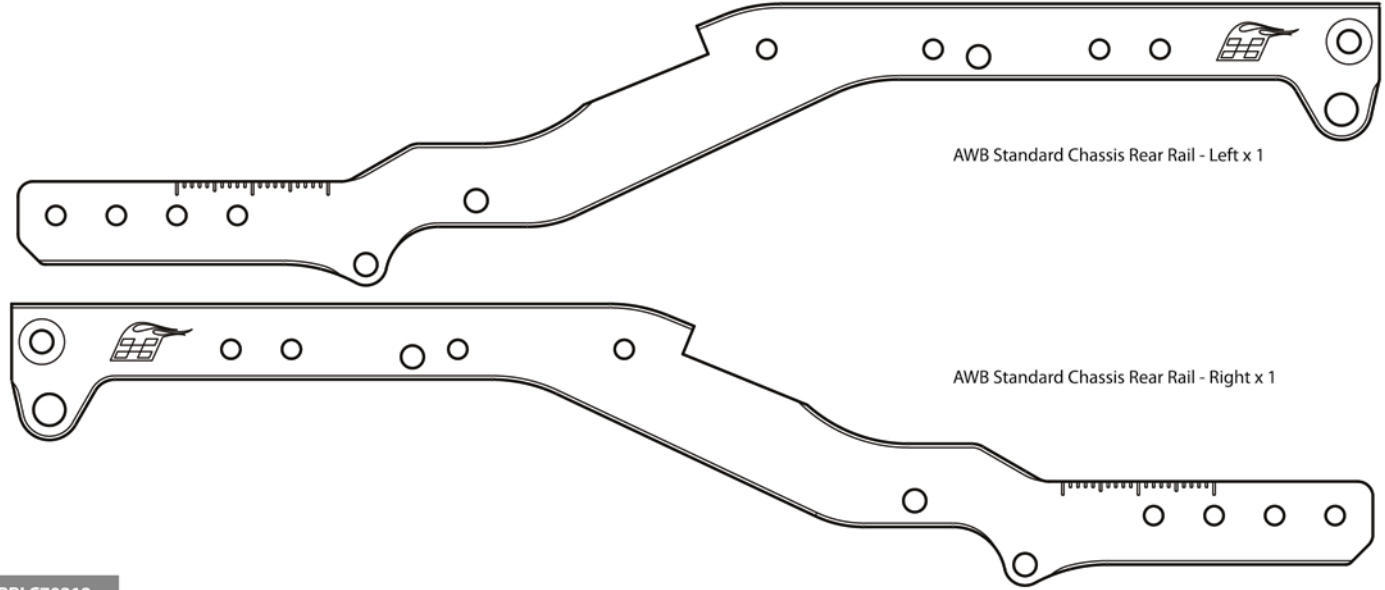

#BRLC70212

13

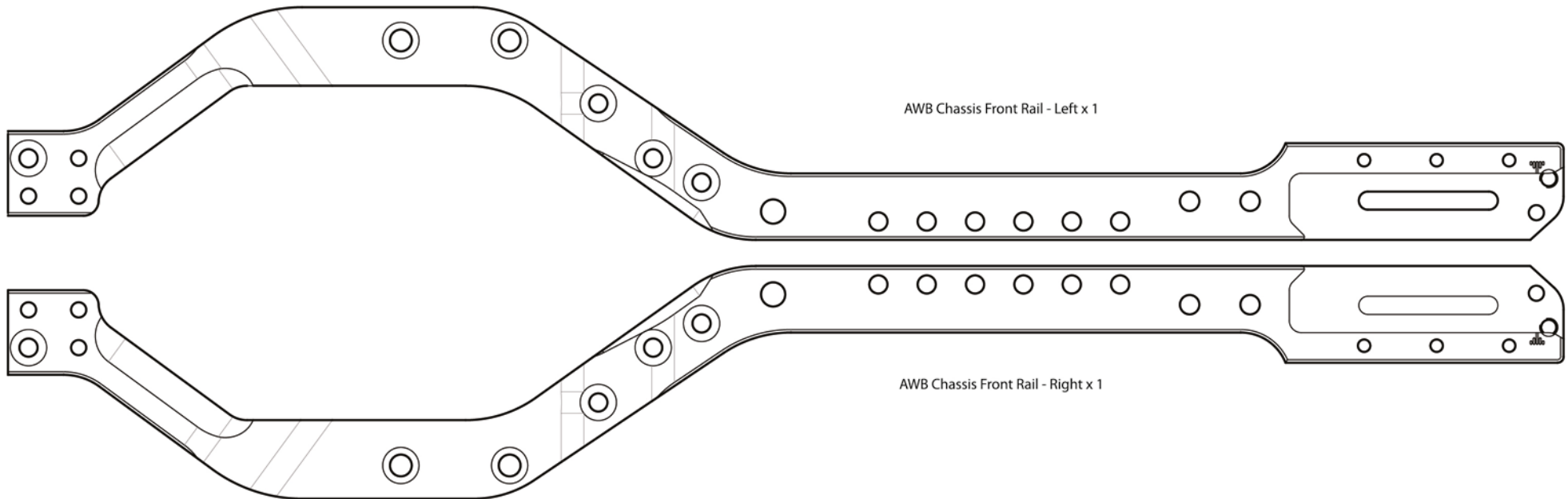

#BRLC70211

PART LOCATION MAP (TOP)

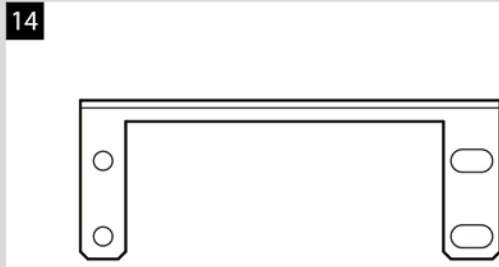
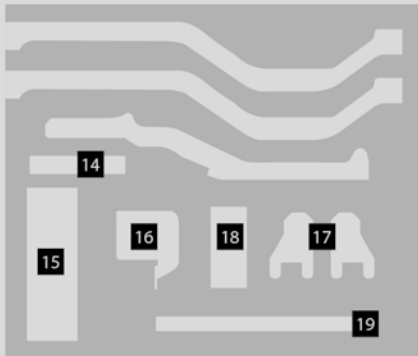

Steering Servo Mount for CMS Setup x 1
#BRLC7016

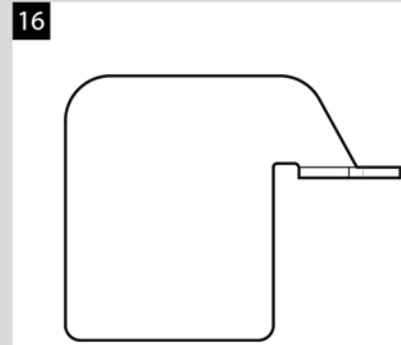

AWB ESC Plate x 1
#BRLC7022

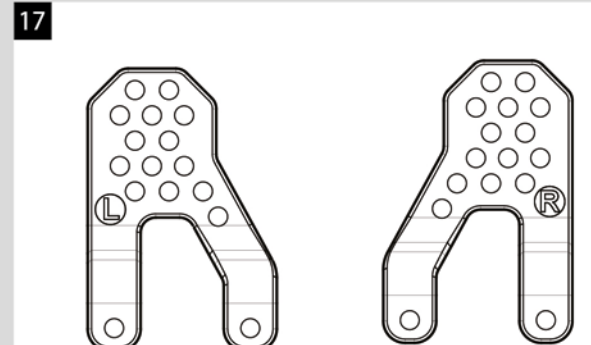

AWB Front Offset Shock Tower
- Left x 1

AWB Front Offset Shock Tower
- Right x 1

#BRLC70218

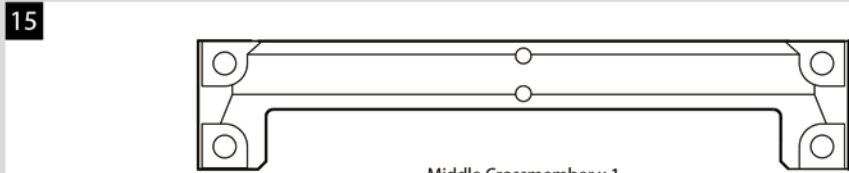

Middle Crossmember x 1
#BRLC7014

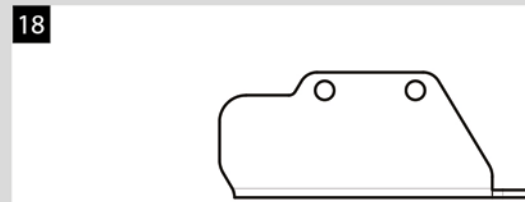

AWB Chassis Side Bracket - Left x 1

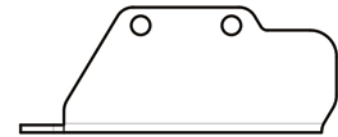

AWB Chassis Side Bracket - Right x 1

#BRLC70214

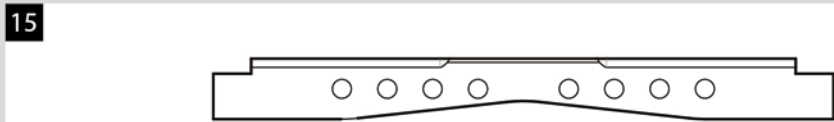

Center Crossmember for BRLC7064 Leaf Spring x 1
#BRLC7064B



AWB Switch Lever
#BRLC70207

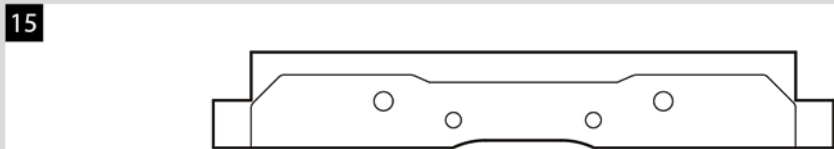

AWB Front Crossmember x 1
#BRLC70202

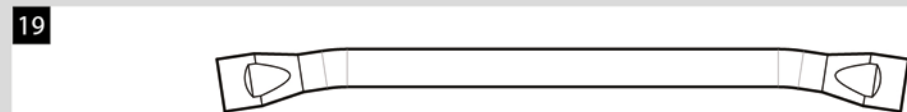

Stainless Steel Tie Rod (1) for BRX80 PHAT™ Axle x 1
#BRD8022A

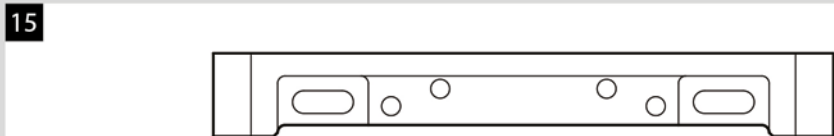

AWB Rear Crossmember x 1
#BRLC70206



Stainless Steel Drag Link - 55mm x 1
#BRLC7050

#BRX020020

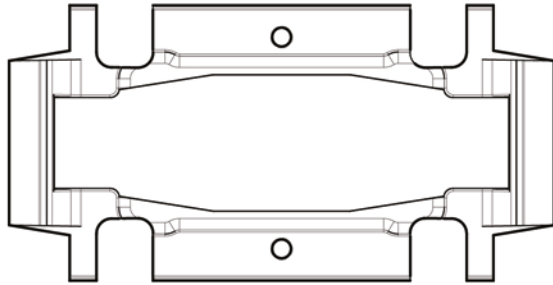

Center Link Mount x 1

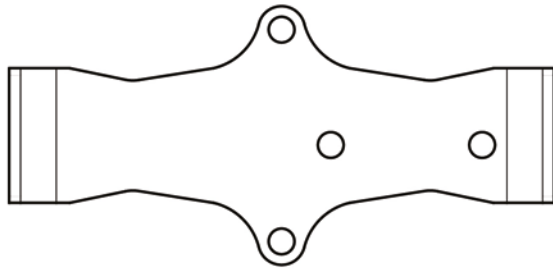

Center Stainless Steel Skid Plate x 1



KUDU™ M4 Nylon Rod End
(Straight 18.5mm) x 15
#BRW750306A

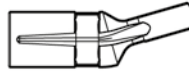

KUDU™ M4 Nylon Rod End (D)
(Upwards 20mm) x 5
#BRW750307D



BADASS™
Stainless Steel Pivot Ball x 20
#BRW750310



M2 Link Rod End Ball Joint x 1
#BRQ90351



AWB Slotted Plate x 2
#BRLC70215



AWB Slotted Washer x 4
#BRLC70216

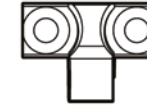

Panhard Axle Mount
#BRX020024



















Panhard Chassis Mount
#BRLC7074A









Panhard Link
#BRLC70233

B LINKS / SHOCKS

- 
M3x8 RS x 2
#BRASBH3008
- 
M3x12 RS x 6
#BRASBH3012
- 
M3x14 RS x 2
#BRASBH3014
- 
M3x16 RS x 6
#BRASBH3016
- 
M3x18 RS x 5
#BRASBH3018
- 
M3x20 RS x 2
#BRASBH3020
- 
M3x26 RS x 2
#BRASBH3026
- 
M3x18 CSS x 2
#BRASFH3018
- 
M4x4 SS x 4
#BRASST4004
- 
M4x16 SS x 10
#BRASST4016
- 
3x6x3
Tapper Spacer x 2
#BRLC7041
- 
3x6x5
Tapper Spacer x 2
#BRLC7040
- 
M3 Nut - Nyloc x 5
#BRASNUTM3
- 
D4x7x1 Stainless Steel x 5
#BRASSP471
- 
D6x1.5 O-Ring x 2
#BRSD06-15
- 
3x6x6
Tapper Spacer x 2
#BRLC7042

A CHASSIS

- 
M2.5x8 CSS x 2
#BRASFH2508
- 
M3x8 CSS x 4
#BRASFH3008
- 
M3x10 CSS x 4
#BRASFH3010
- 
M2.5x6 RS x 8
#BRASBH2506
- 
M3x6 RS x 2
#BRASBH3006
- 
M3x8 RS x 12
#BRASBH3008
- 
M3x12 RS x 8
#BRASBH3012

C WHEELS

- 
12mm Aluminum
Wheel Hex Adapter (8mm) x 4
#BRLC7056
- 
M4 Nuts - Nyloc x 4
#BRASNUTM4
- 
M3x3 SS x 4
#BRASST3003
- 
D2x10 Pin x 4
#BRASPIN210



(Not included in Builder's Kit BR8014)

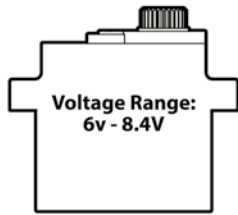

JX Waterproof HV Mini Servo x 1
#JX/PDI-HV1151MG

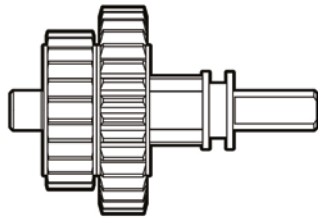

2-Speed Gear Unit x 1
#BRLC7044E



Spur Gear Mount x 1
#BRLC7030

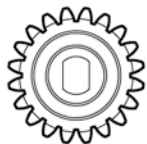

Spur Gear 20T x 2
#BRLC7029-20T



Bearing Holder x 1
#BRX020029A



Spur Gear 12T x 1
#BRLC7029-12T



Spur Gear 15T x 1
#BRLC7029-15T



D7x11x3 Ball Bearing x 1
#BBZMR1172RS



D5x11x4 Ball Bearing x 7
#BBZMR1152RS

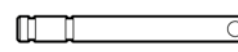

Shift Rod x 1
#BRLC7045C



Input Shaft x 1
#BRLC7044B

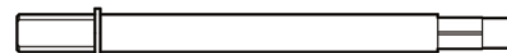

High Efficiency Coupling Shaft x 1
#BRLC7209

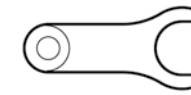

Shifter x 1
#BRLC7045B

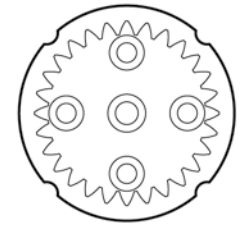

Internal Spur Gear 28T x 1
#BRLC7031

D GEARBOX / TRANSFER CASE

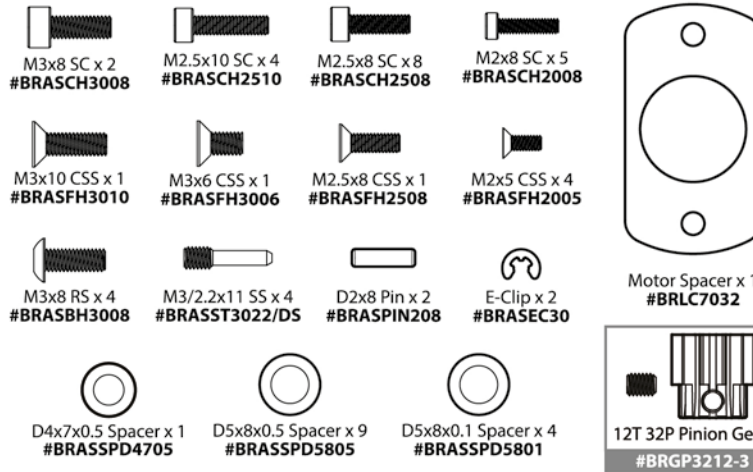

G GEARS, SHAFTS & BEARINGS - TRANSFER CASE

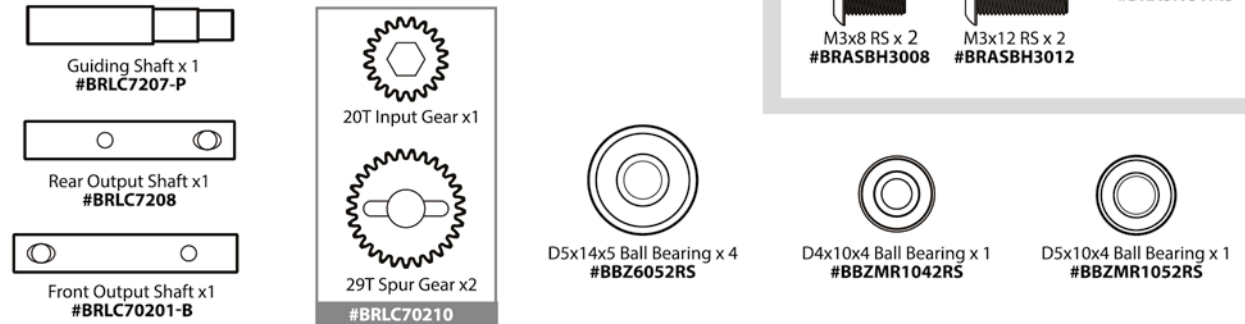

H GEARS, SHAFTS & BEARINGS - GEARBOX

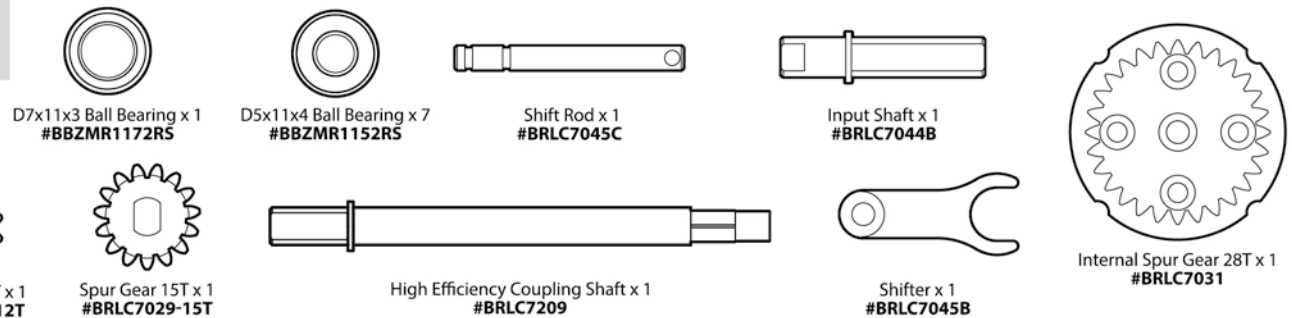

E RECEIVER BOX



F SERVOS

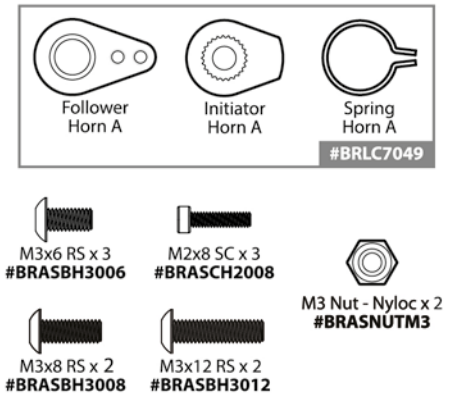

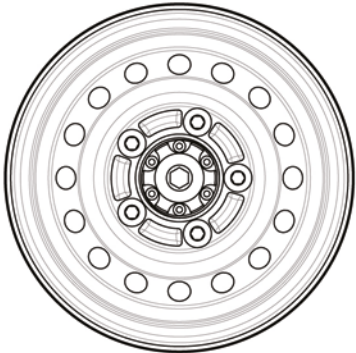

1.55" 16-Hole Classic Steelie Reversible
Beadlock Wheels (Front)
w/ XT504 Hubs x 2 (Gun Metal)
#BRW780955FGM
(Not included in Builder's Kit BR8014)



Rear Upper Link x 2
#BRLC70228

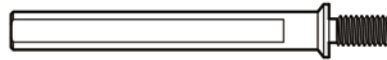

50mm Rear Lower Link Spline Shaft x 2
#BRLC70229

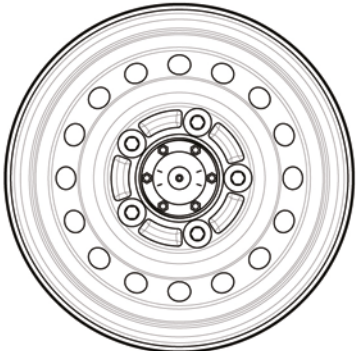

1.55" 16-Hole Classic Steelie Reversible
Beadlock Wheels (Rear)
w/ XT504 Hubs x 2 (Gun Metal)
#BRW780955RGM
(Not included in Builder's Kit BR8014)

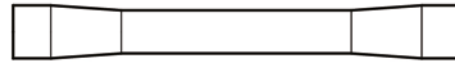

Front Upper Link x 1
#BRLC70230

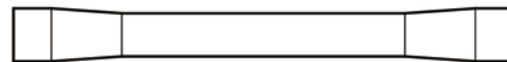

Front Lower Link x 2
#BRLC70231



Joint Retainer x 10
#BRSHJR



BADASS™ Stainless
Steel Pivot Ball x 8
#BRW750310

#BRLC70221

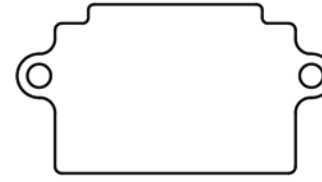

Stainless Steel Sealing Plate x 1

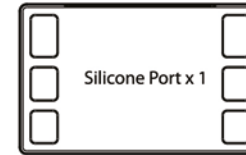

Silicone Port x 1

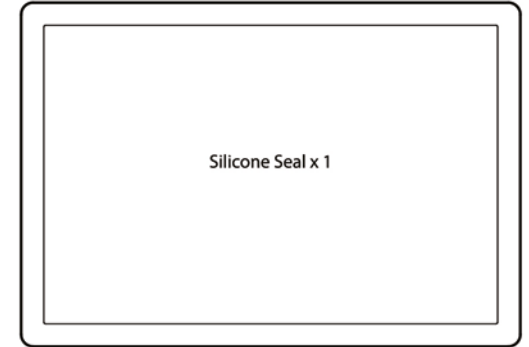

Silicone Seal x 1

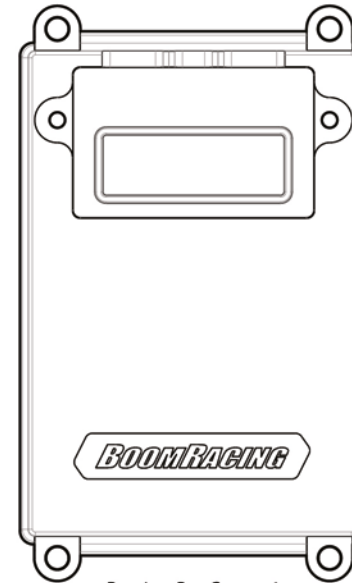

Receiver Box Cover x 1

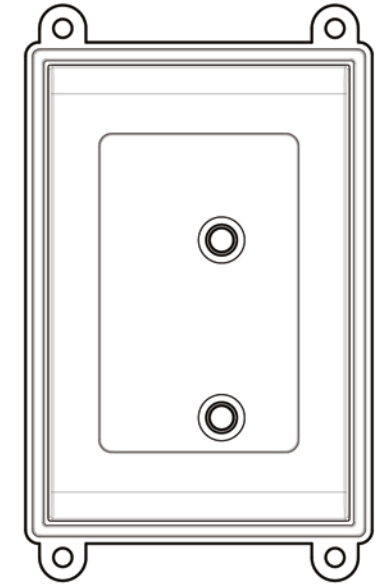

Receiver Box x 1

#BRLC70232

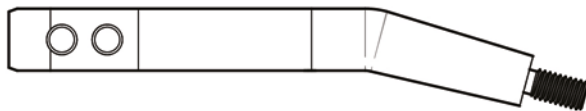

Rear Lower Link Barrel (R) x 1

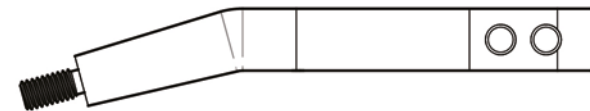

Rear Lower Link Barrel (L) x 1



Extension Cable x 2
#BRLC7059

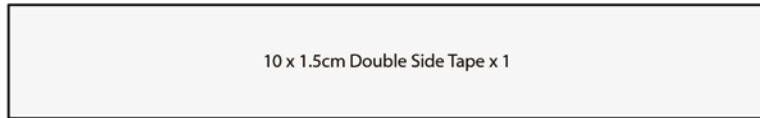

10 x 1.5cm Double Side Tape x 1

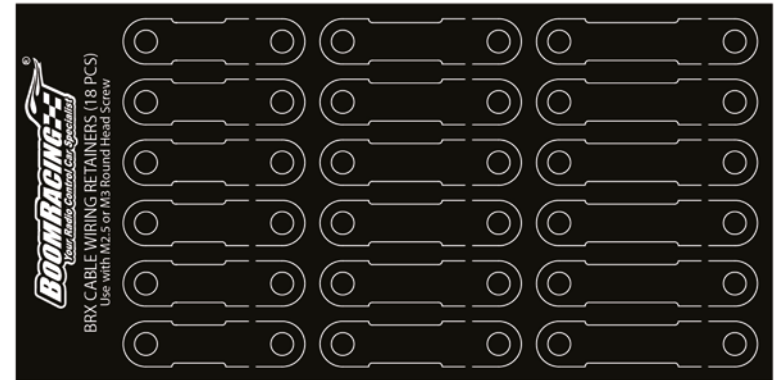

Cable Wiring Retainers
#BRT10037

#BRT10028

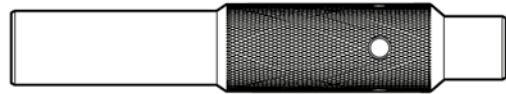

Socket 5.5mm/7mm

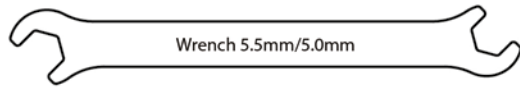

Wrench 5.5mm/5.0mm

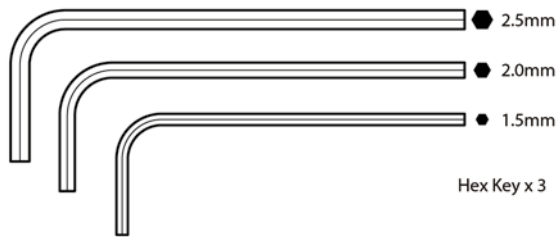

2.5mm
2.0mm
1.5mm
Hex Key x 3

#BRT10053

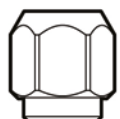

Pivot Ball Tool x 1



M3x18 RS x 1
#BRASBH3018

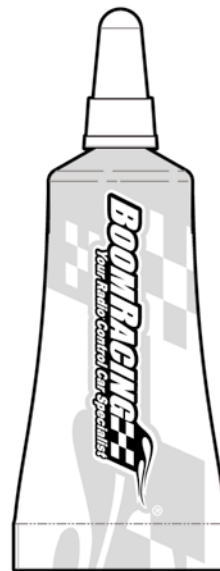

Black Graphite Grease 10g x 1
#BRGRS1055-10

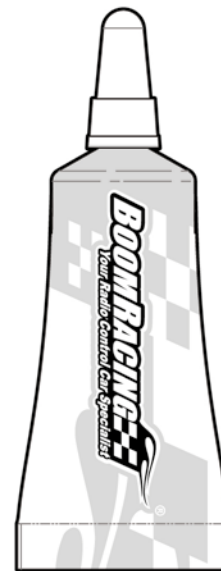

Silicone Grease 10g x 1
#BRGRS10274-10



30WT Shock Oil 15ml x 1
(Available separately in 60ml)
#BRSHK030



242 Thread Lock 2g x 1
(Available separately in 10g)
#BRGRS242



1- CHASSIS RAIL

Parts Needed:



Slotted Washer x 4



Slotted Retainer x 2

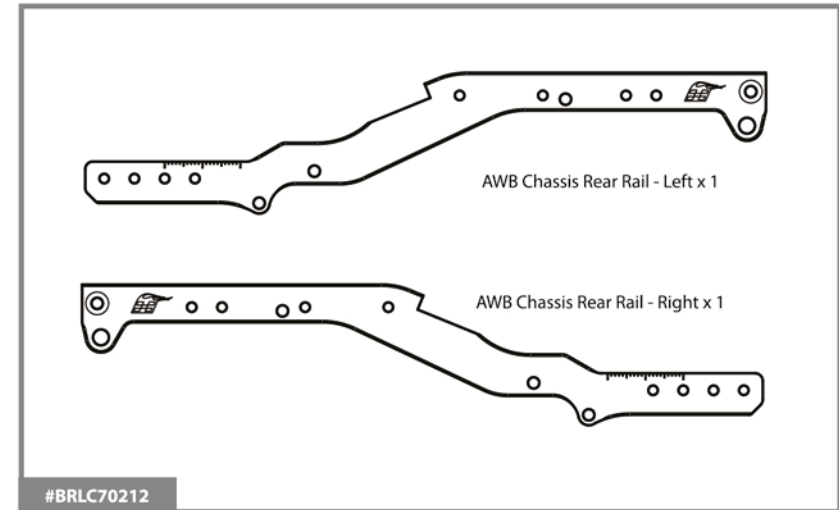
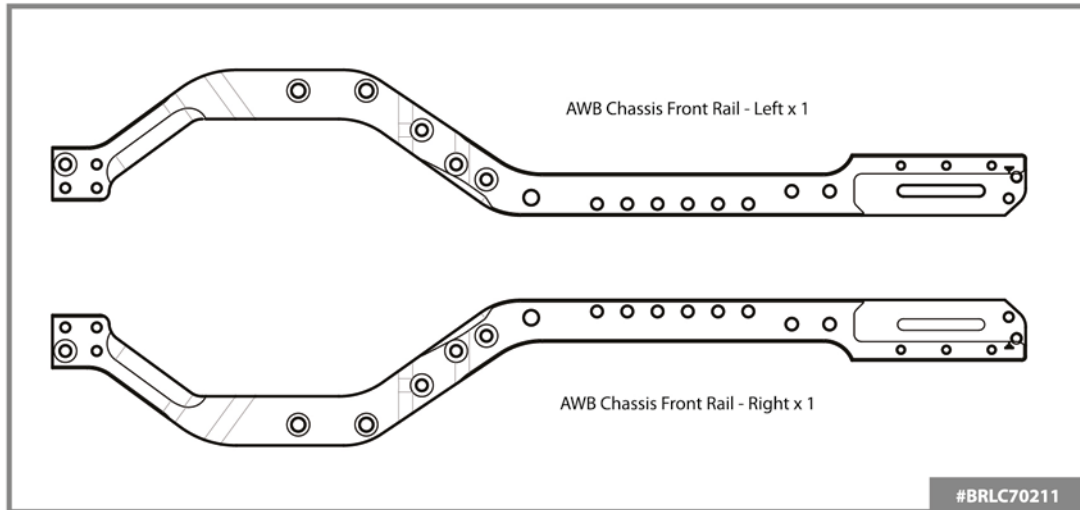
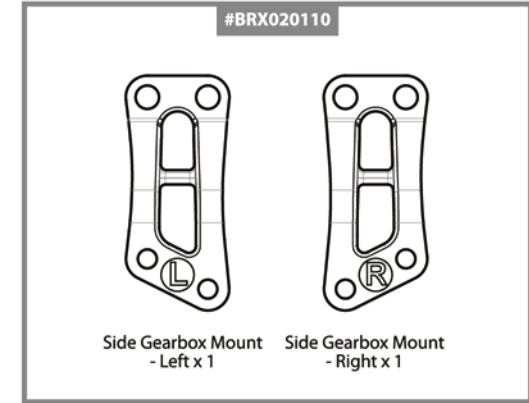
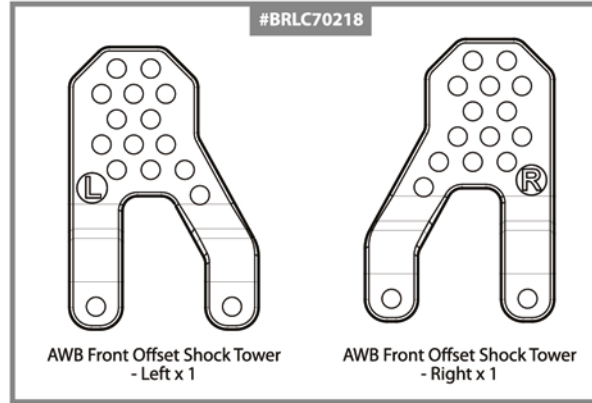
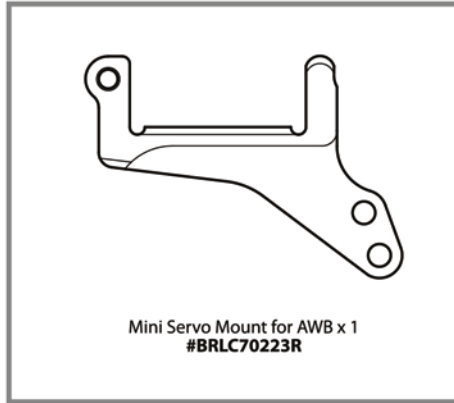

A CHASSIS



Apply thread lock to all screws.
(Do not use red thread lock)



M3x8 RS x 6
#BRASBH3008



M3x10 CSS x 4
#BRASFH3010

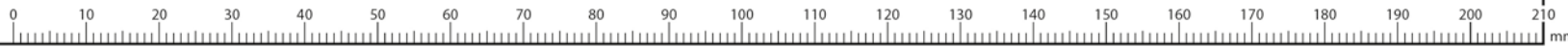
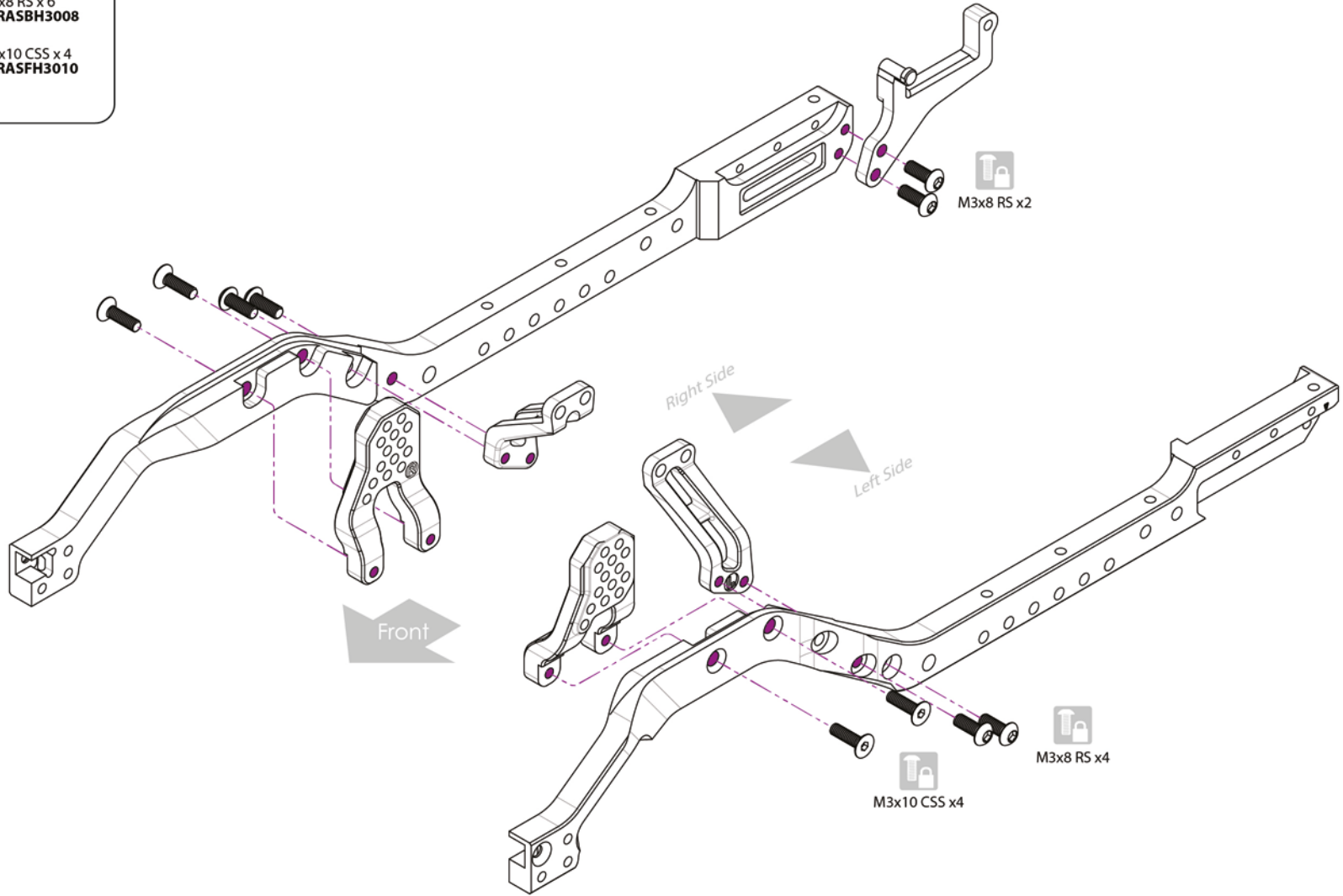

A CHASSIS

M3x12 RS x 4
#BRASBH3012



Apply thread lock to all screws.
(Do not use red thread lock)

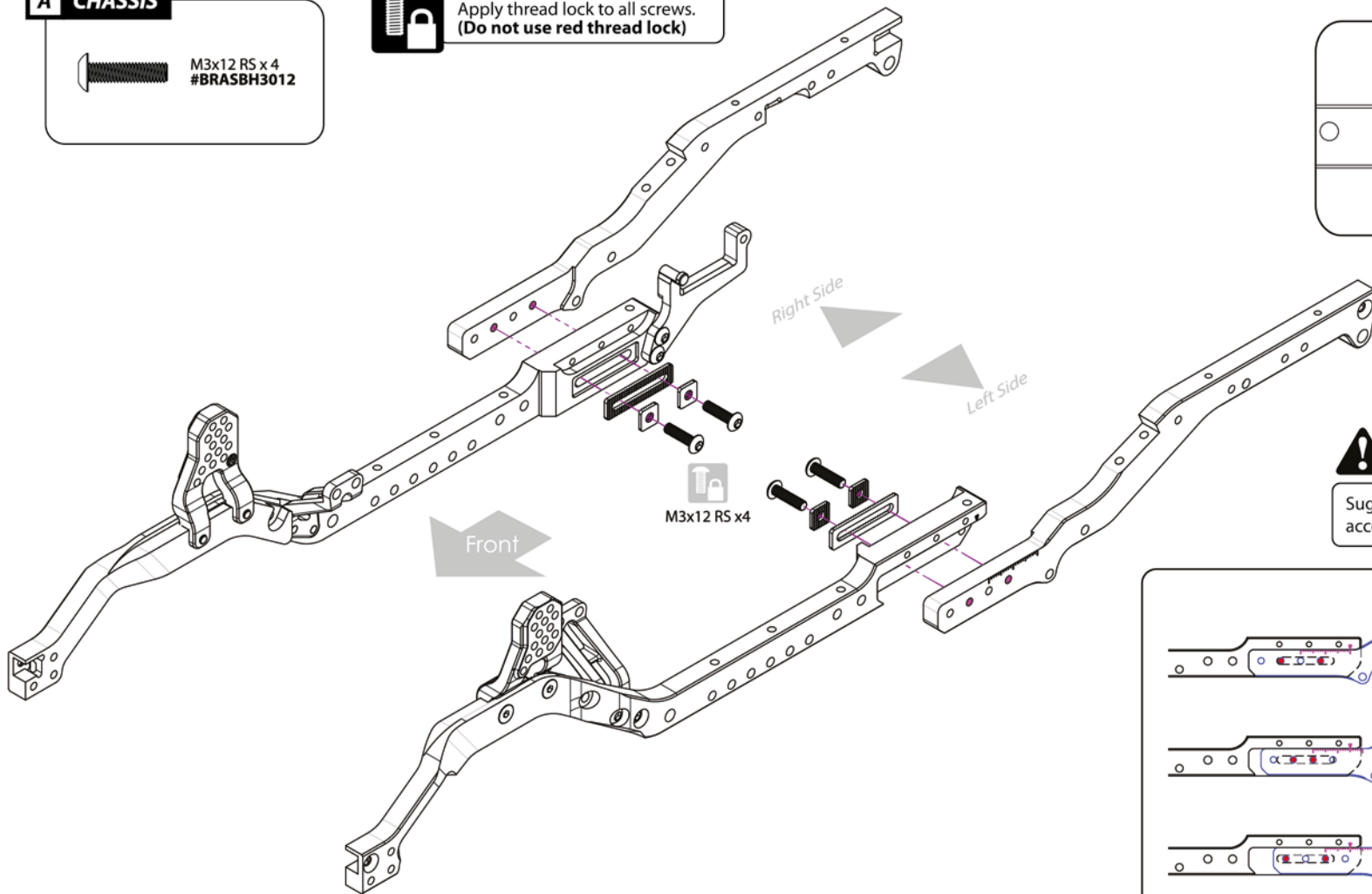
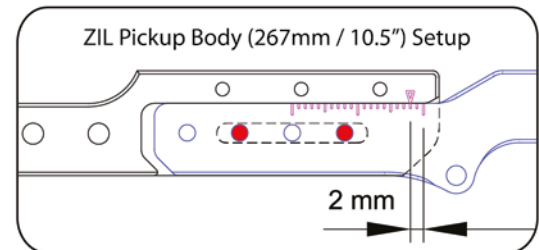

Suggested screw hole locations on the rear rails to accommodate optional chassis length configurations.

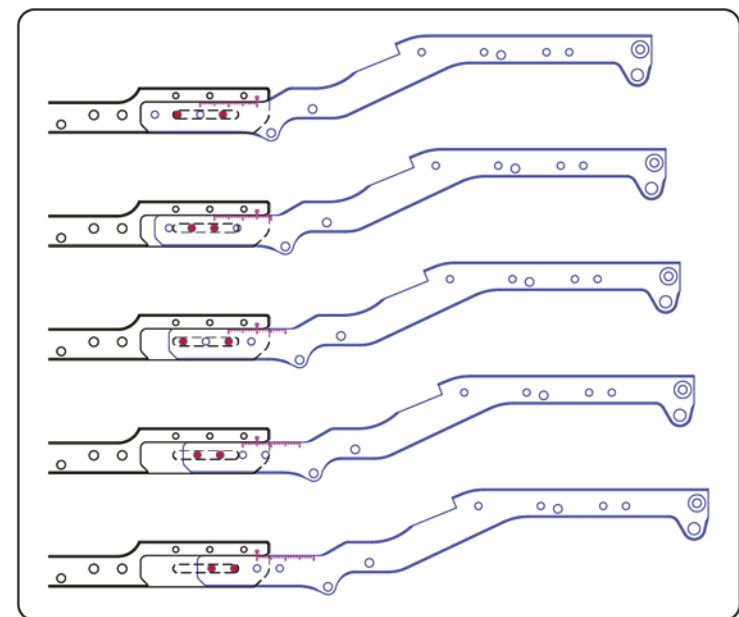

2 - CHASSIS

Parts Needed:



Steering Servo Mount for CMS Setup x 1
#BRLC7016

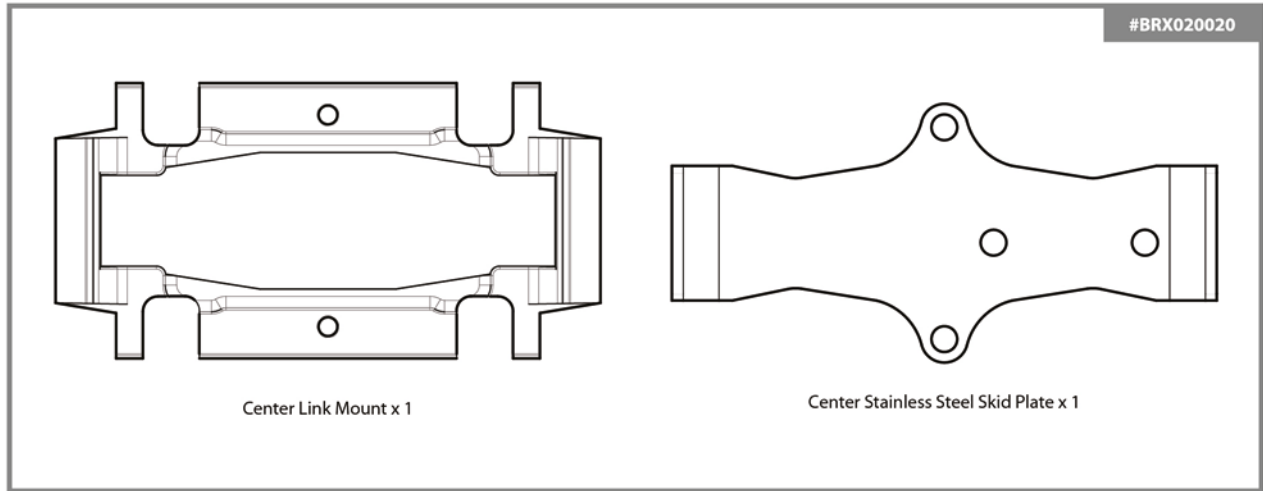

Center Link Mount x 1

Center Stainless Steel Skid Plate x 1

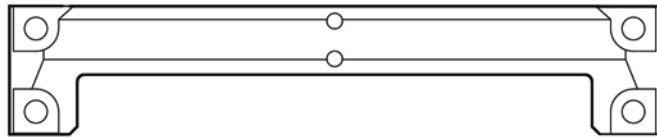

Middle Crossmember x 1
#BRLC7014



Center Crossmember for BRLC7064 Leaf Spring x 1
#BRLC7064B

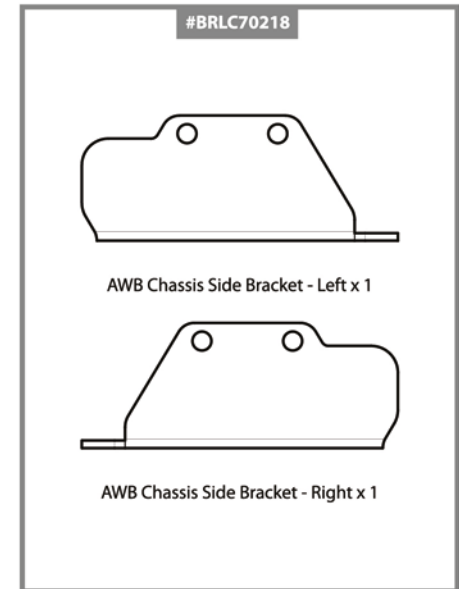

AWB Chassis Side Bracket - Left x 1

AWB Chassis Side Bracket - Right x 1

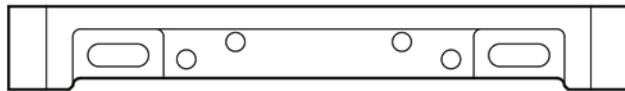

AWB Rear Crossmember x 1
#BRLC70206







AWB Front Crossmember x 1
#BRLC70202

CHASSIS

CHASSIS

A CHASSIS

-  M3x8 RS x 6
#BRASBH3008
-  M3x12 RS x 4
#BRASBH3010
-  M2.5x8 CSS x 2
#BRASFH2508
-  M3x8 CSS x 4
#BRASFH3008

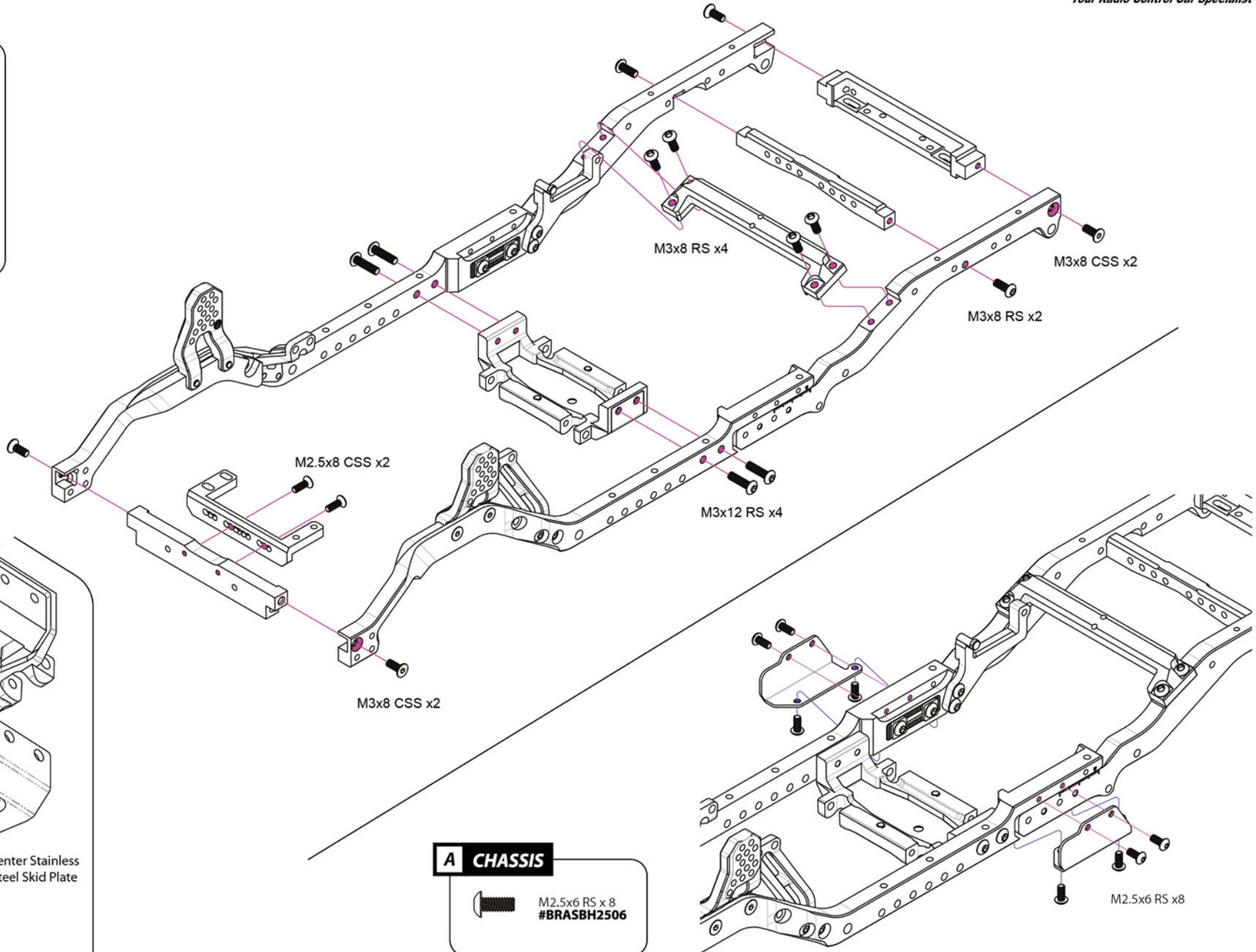

PRE-ASSEMBLED SKID PLATE

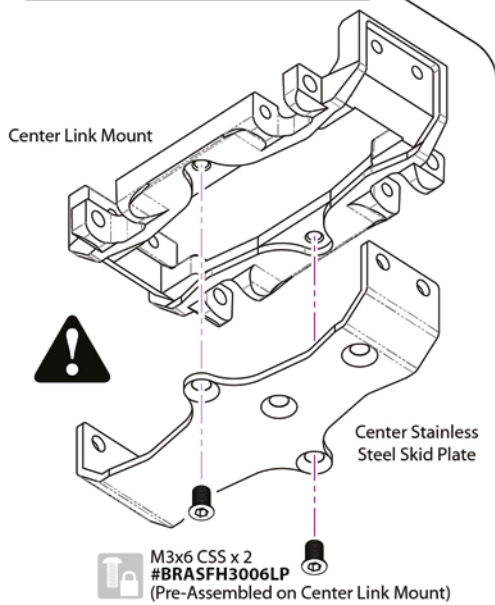

A CHASSIS

-  M2.5x6 RS x 8
#BRASBH2506

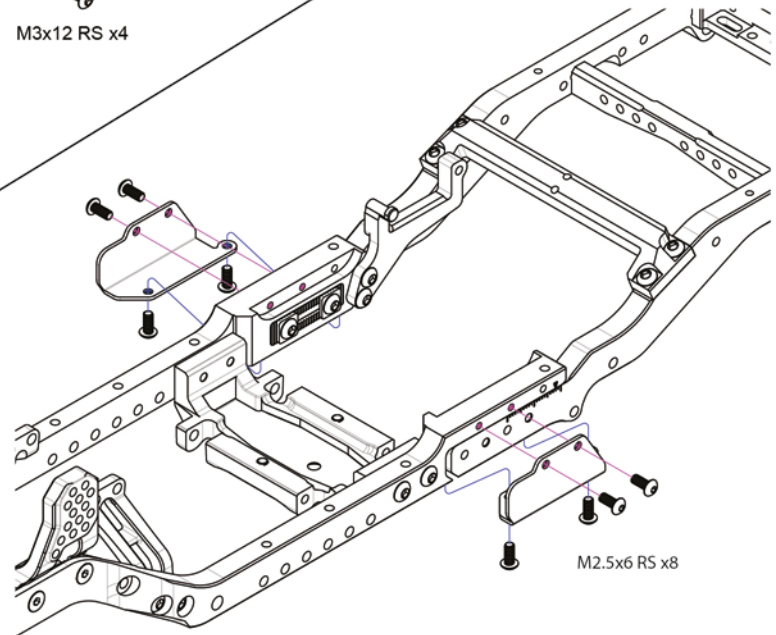

CHASSIS

CHASSIS

3 - GEARBOX

Parts Needed:

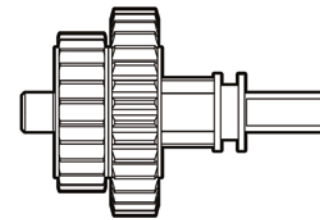
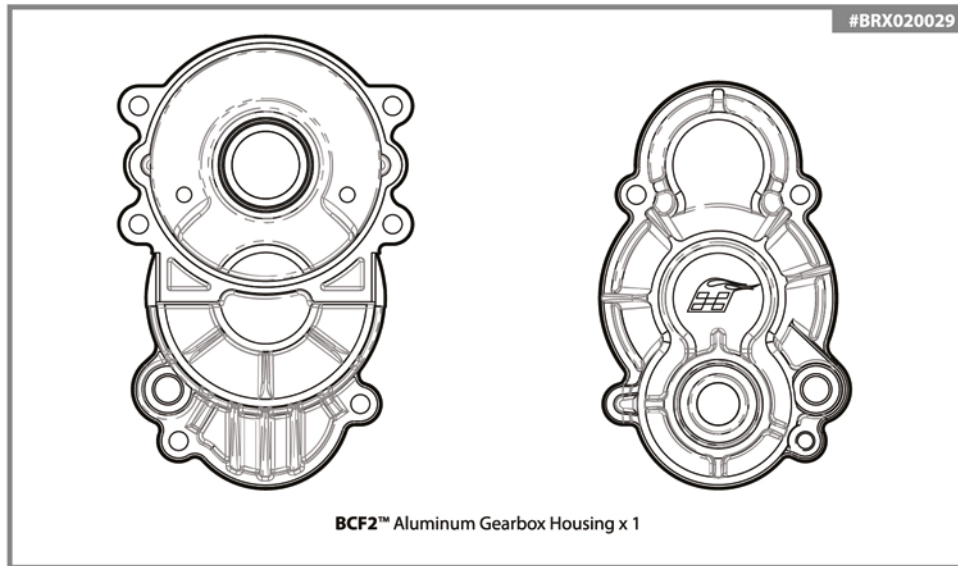

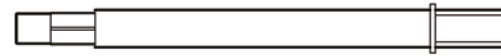
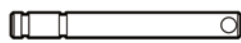
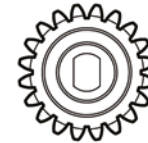
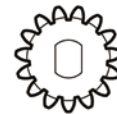
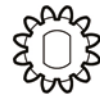
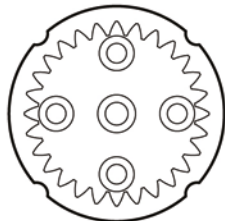

H GEARS, SHAFTS & BEARINGS - GEAR BOX



3.1

D GEARBOX / TRANSFER CASE

-  M2.5x8 CSS x 1
#BRASFH2508
-  M2x5 CSS x 4
#BRASFH2005

 Fit the Spur Gear Mount onto the Spur Gear by tightening M2x5 countersunk screws.

To install or remove the spur gear from the gearbox, align the spur gear as pictured and temporarily insert two M3 screws** to act as stoppers.

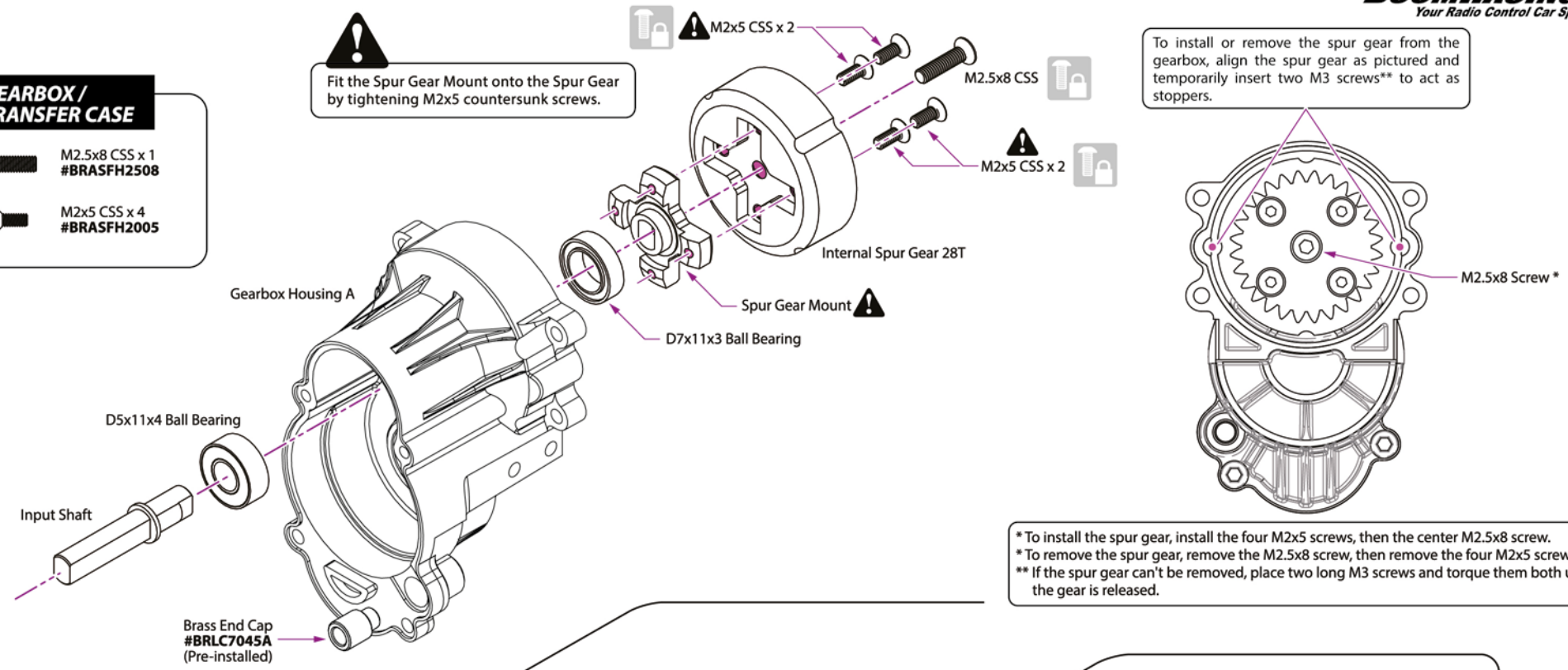

*To install the spur gear, install the four M2x5 screws, then the center M2.5x8 screw.
*To remove the spur gear, remove the M2.5x8 screw, then remove the four M2x5 screws.
** If the spur gear can't be removed, place two long M3 screws and torque them both until the gear is released.

3.2

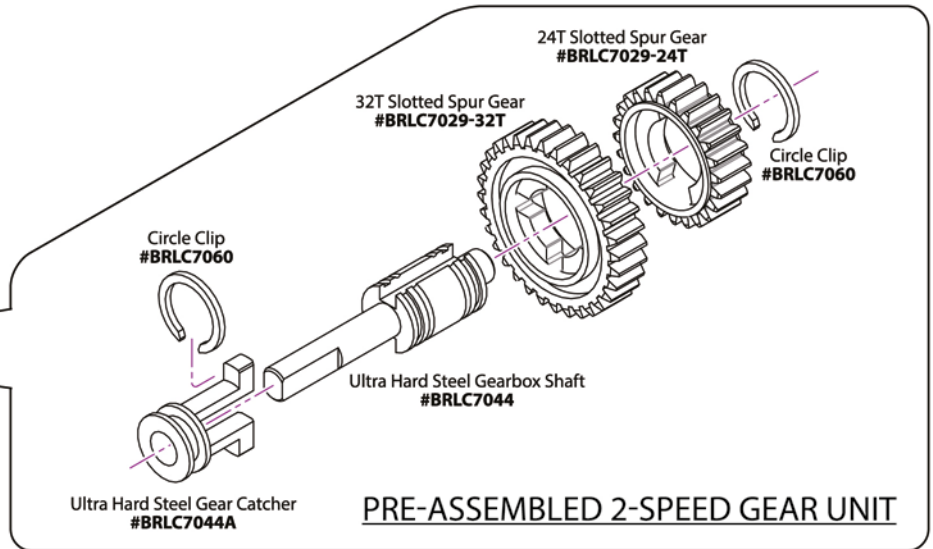
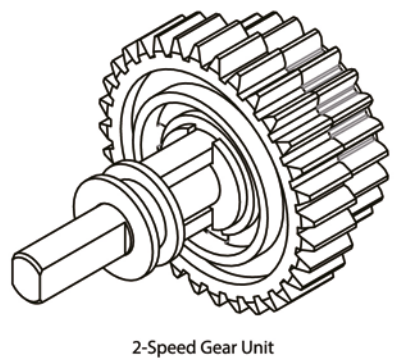

GEARBOX

GEARBOX

3.3

D GEARBOX / TRANSFER CASE

-  D5x8x0.5 Spacer x 4
#BRASSPD5805
-  M3 E-Clip x 2
#BRASEC30
-  D5x8x0.1 Spacer x 4
#BRASSPD5801

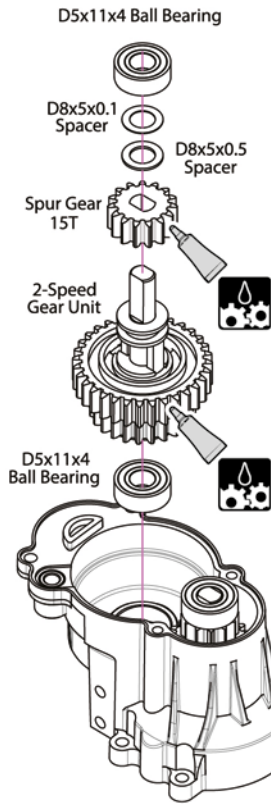
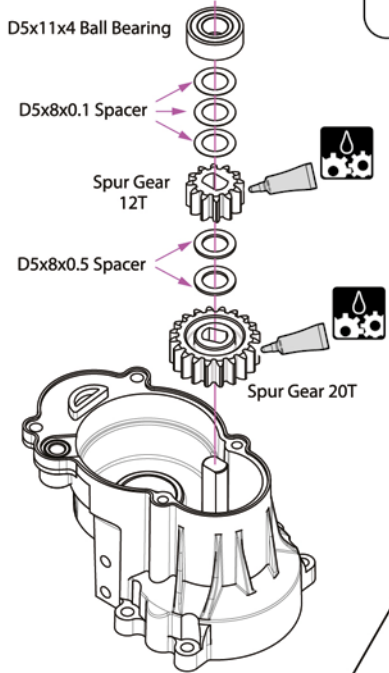

Black Graphite Grease 10g x 1
#BRGRS1055-10

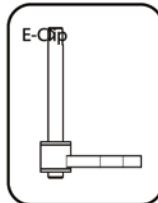
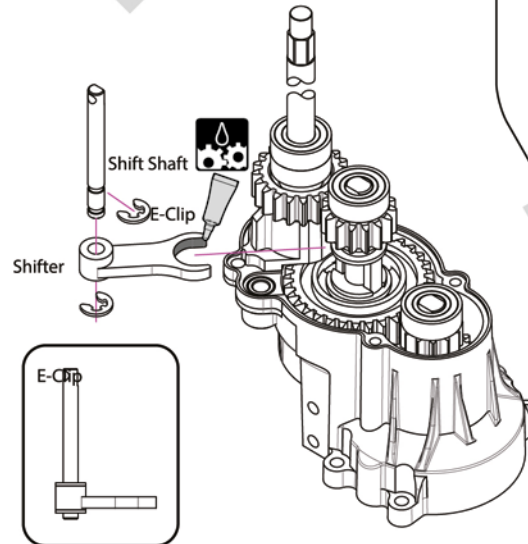
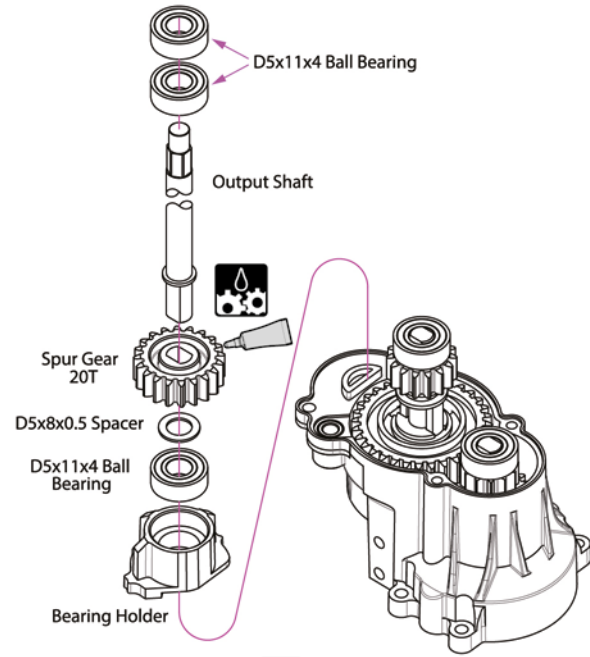

D GEARBOX / TRANSFER CASE

-  M2.5x10 SC x 4
#BRASCH2510

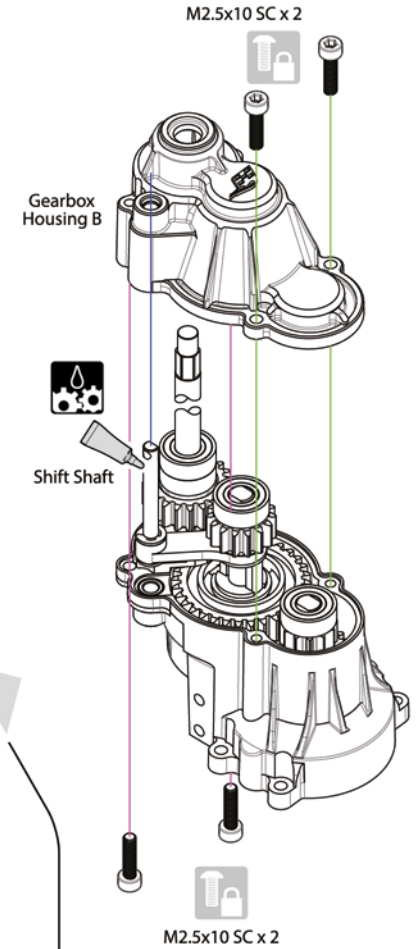

4 - TRANSFER CASE

Parts Needed:

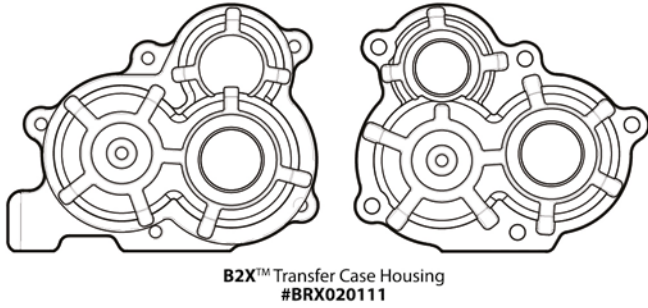

D GEARBOX / TRANSFER CASE

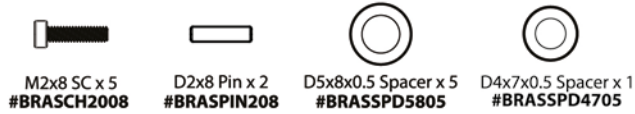

G GEARS, SHAFTS & BEARINGS - TRANSFER CASE

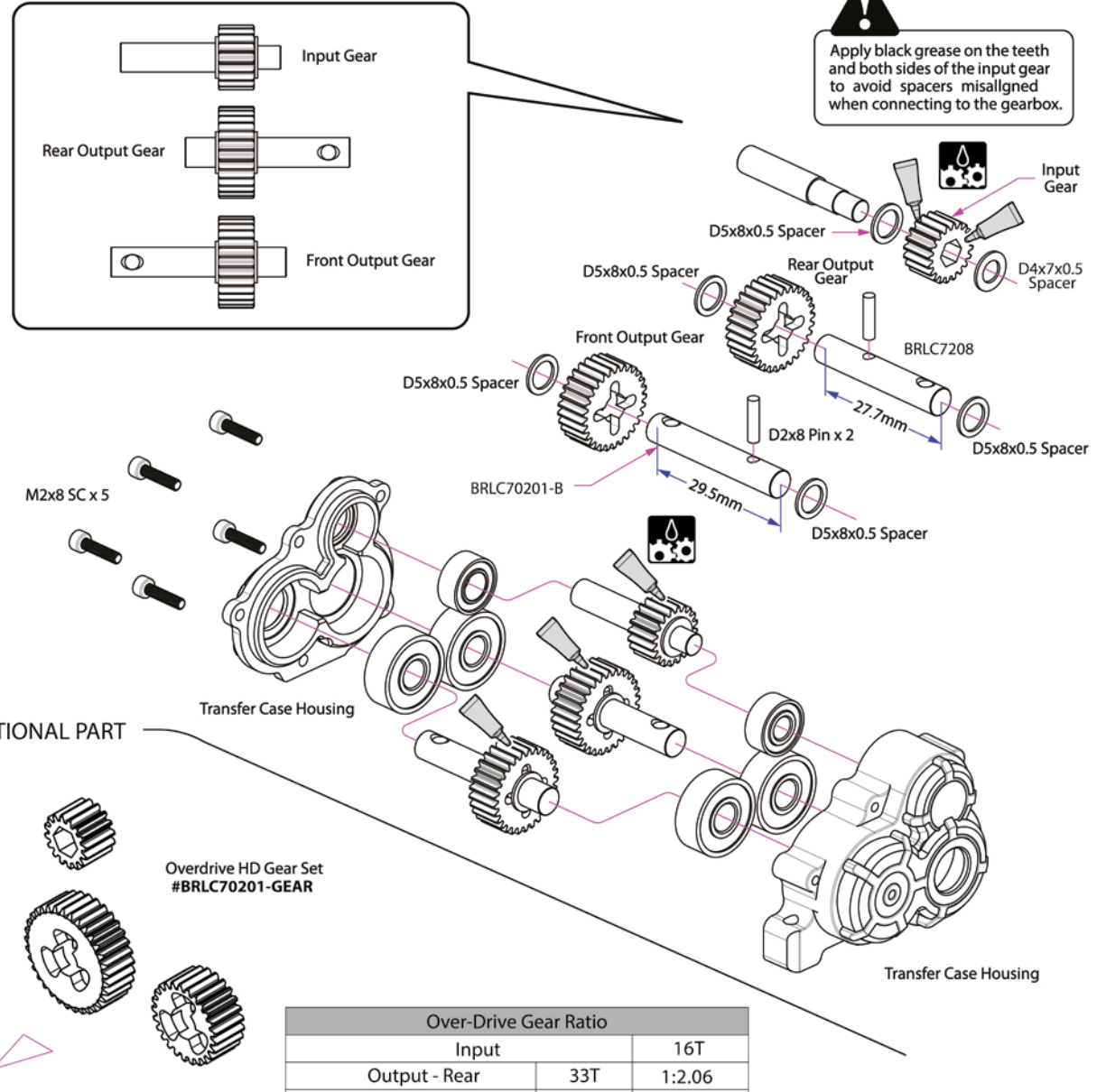
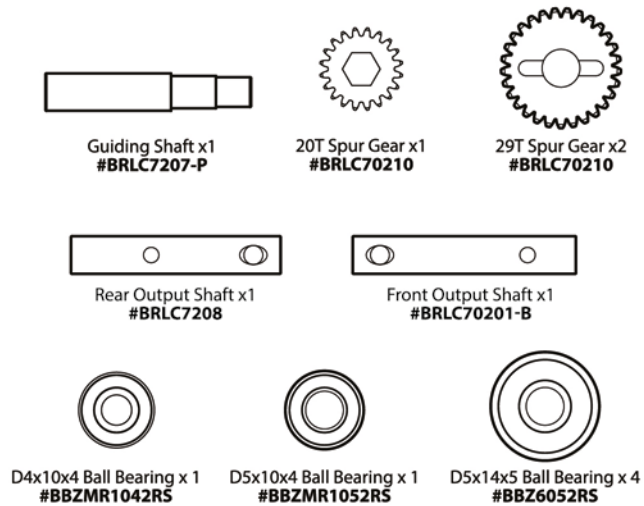

Over-Drive Gear Ratio		
Input		16T
Output - Rear	33T	1:2.06
Output - Front	25T	1:1.56
Rear to Front output speed ratio		1:1.32

5 - GEARBOX & TRANSFER CASE

Parts Needed:

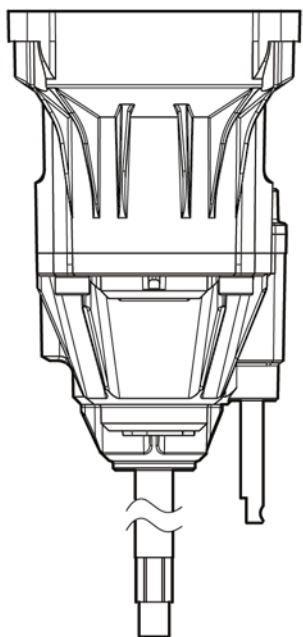

Complete **BCF2™** Gearbox

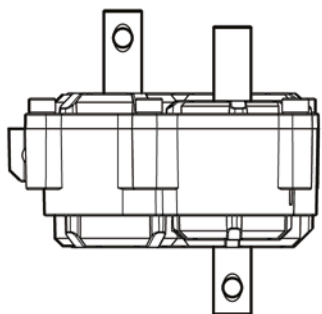

Complete **B2X™** Transfer Case

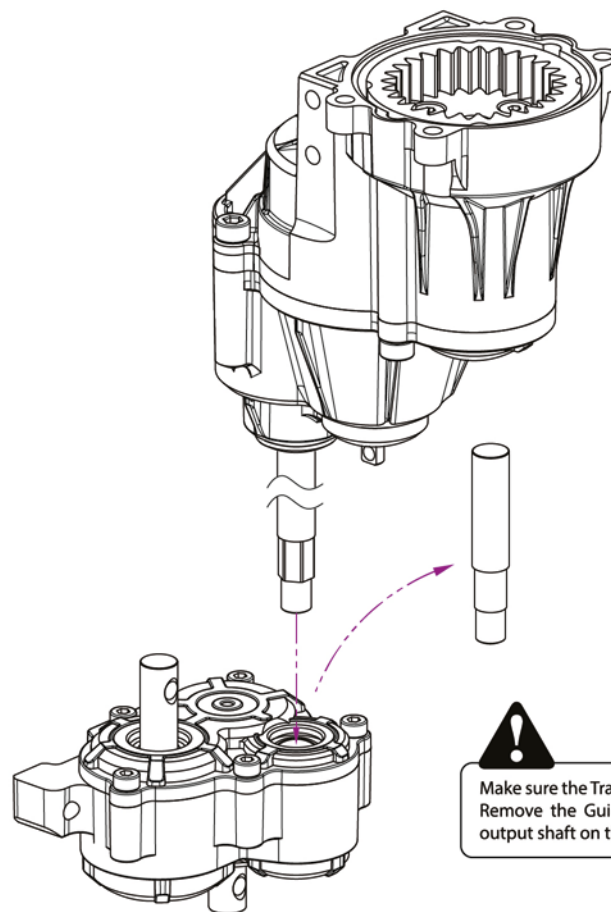



! Make sure the Transfer Case is kept in the upwards position. Remove the Guiding Shaft carefully and then insert the output shaft on the Gearbox into the Transfer Case.

GEARBOX & TRANSFER CASE

GEARBOX & TRANSFER CASE

D GEARBOX / TRANSFER CASE

-  M3x8 RS x 4
#BRASBH3008
-  M3x6 CSS x 1
#BRASFH3006
-  M3x10 CSS x 1
#BRASFH3010

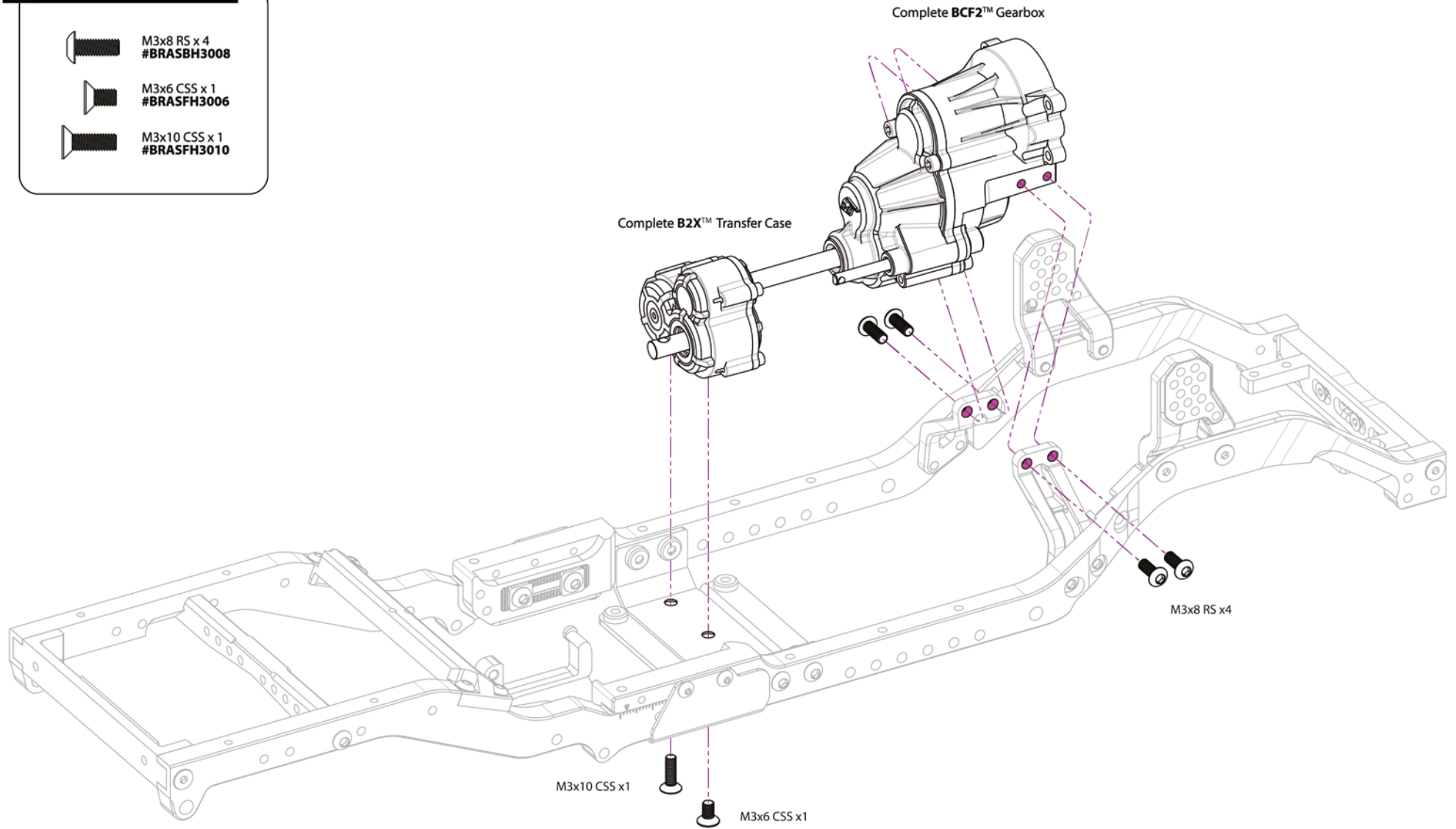

6 - LINK SYSTEM

Parts Needed:

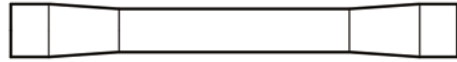

Front Upper Link x 1
#BRLC70230



Rear Upper Link x 2
#BRLC70228

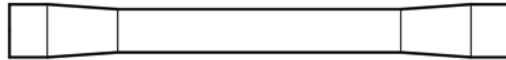

Front Lower Link x 2
#BRLC70231

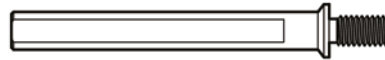

50mm Rear Lower Link Spline Shaft x 2
#BRLC70229

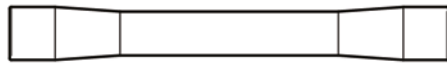

Panhard Link x 1
#BRLC70233



Panhard Chassis Mount
#BRLC7074A

B LINKS / SHOCKS

M4x4 SS x 4
#BRASST4004

M4x16 SS x 8
#BRASST4016

BADASS™
Stainless Steel Pivot Ball x 16
#BRW750310

KUDU™ M4 Nylon Rod End (A)
(Straight 18.5mm) x 11
#BRW750306A

KUDU™
M4 Nylon Rod End (D)
(Upwards 20mm) x 5
#BRW750307D

B LINKS / SHOCKS

D4x7x1 Stainless
Steel Spacer x 3
#BRASS471

Additional spacers provided for link adjustments.

#BRLC70232

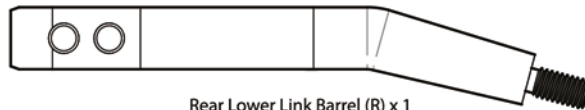

Rear Lower Link Barrel (R) x 1

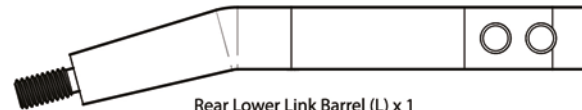

Rear Lower Link Barrel (L) x 1

PIVOT BALL INSTALLATION & REMOVAL

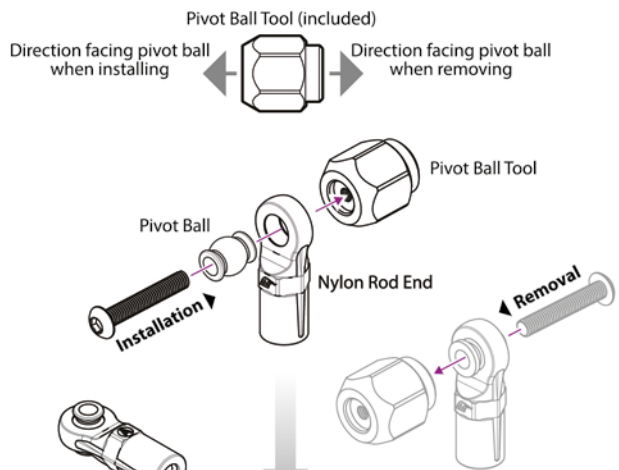

- Install the set screw into the rod end before inserting into the link.
- Tip: Use a 2.0 Hex Driver to torque the set screw into the rod end.

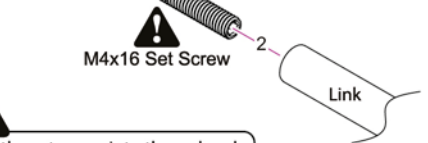

Front Upper Link

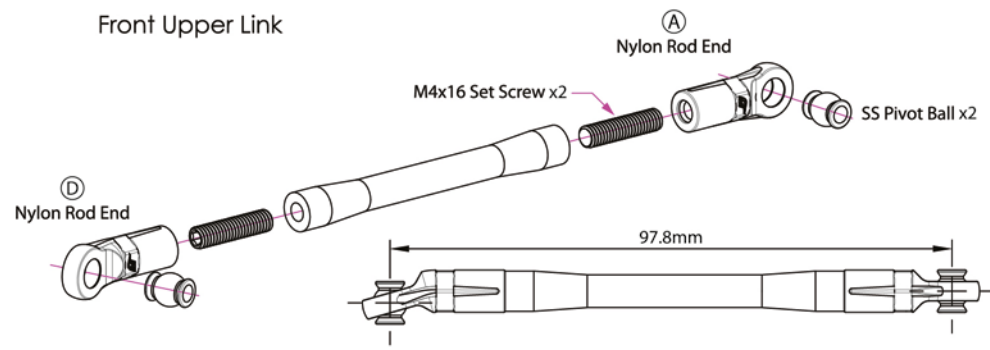

Front Lower Link (x2)

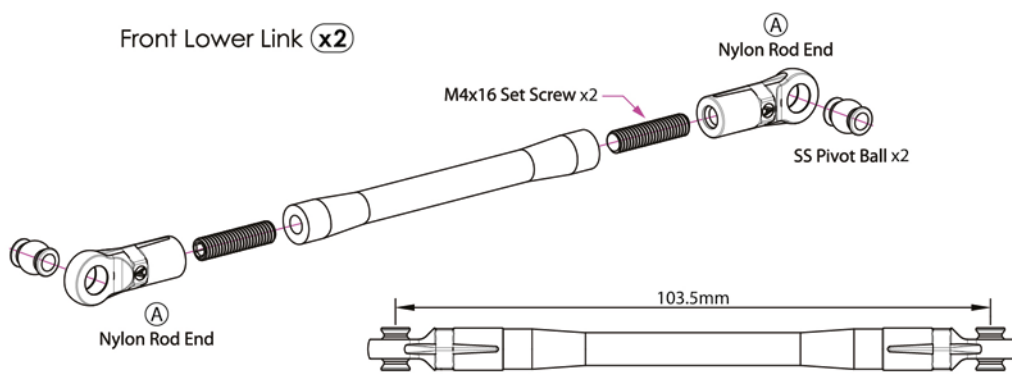

Panhard Link

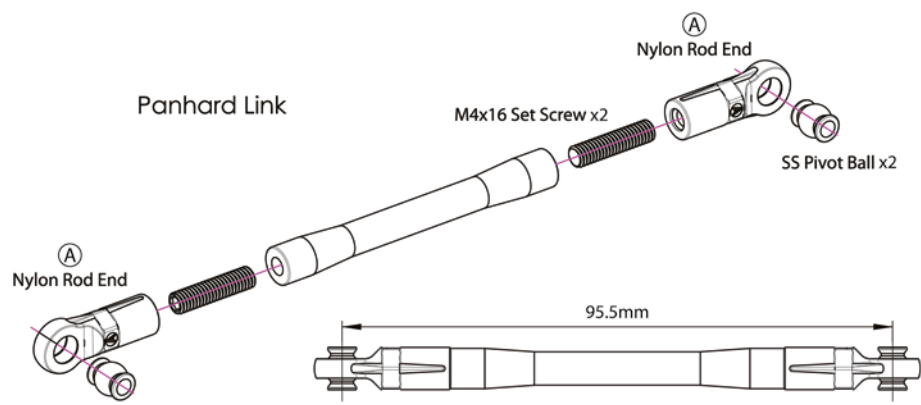

Rear Upper Link (x2)

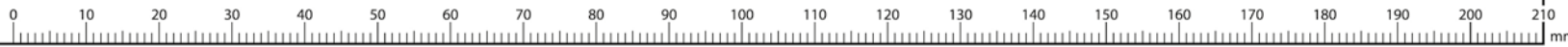
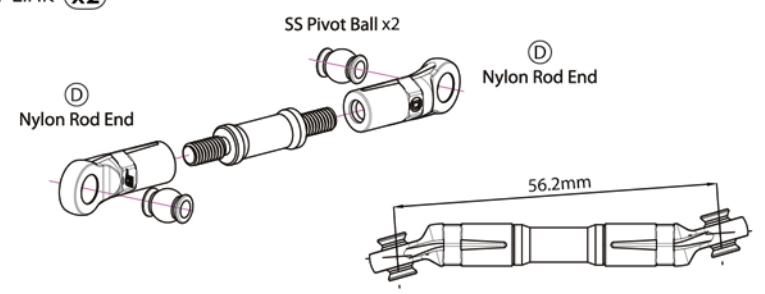

LINK SYSTEM

LINK SYSTEM

Assembly of Left & Right Adjustable Rear Lower Links

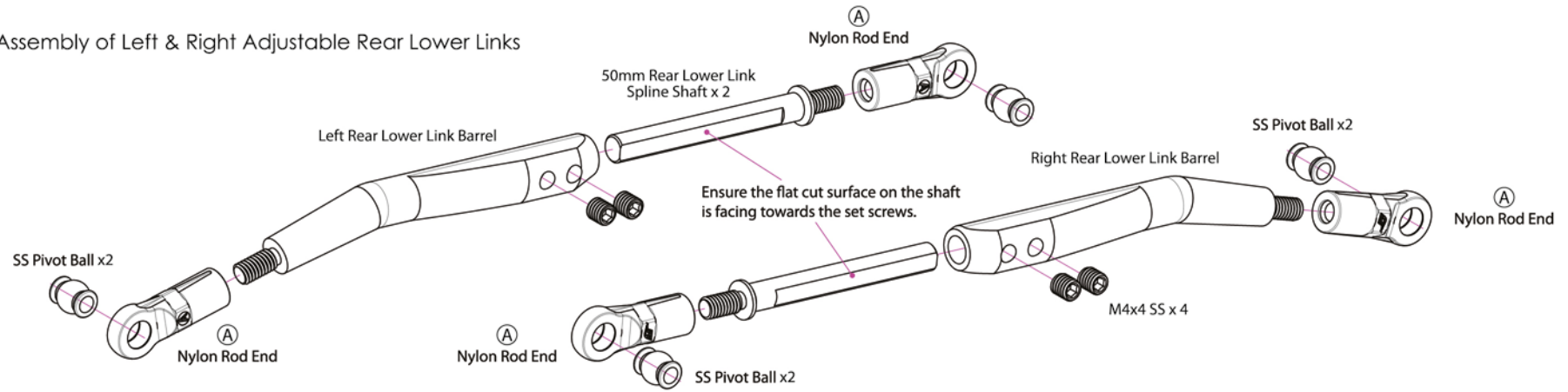

Adjustable Rear Lower Links Stock Setup

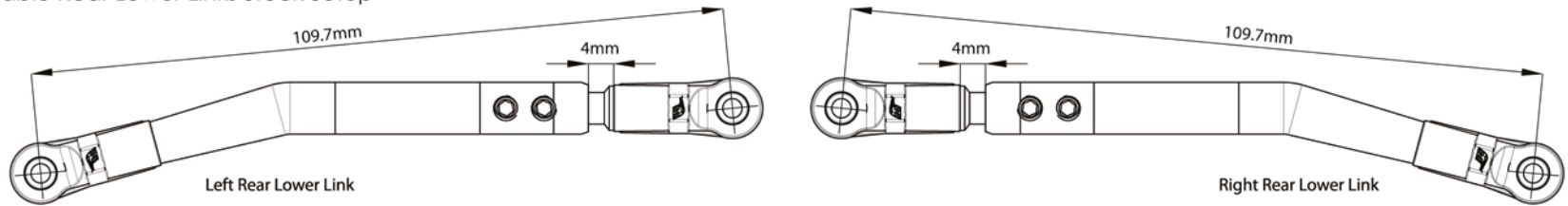

Below diagram shows the nylon rod ends (A and D) used in the assembly for each specific link (top view).

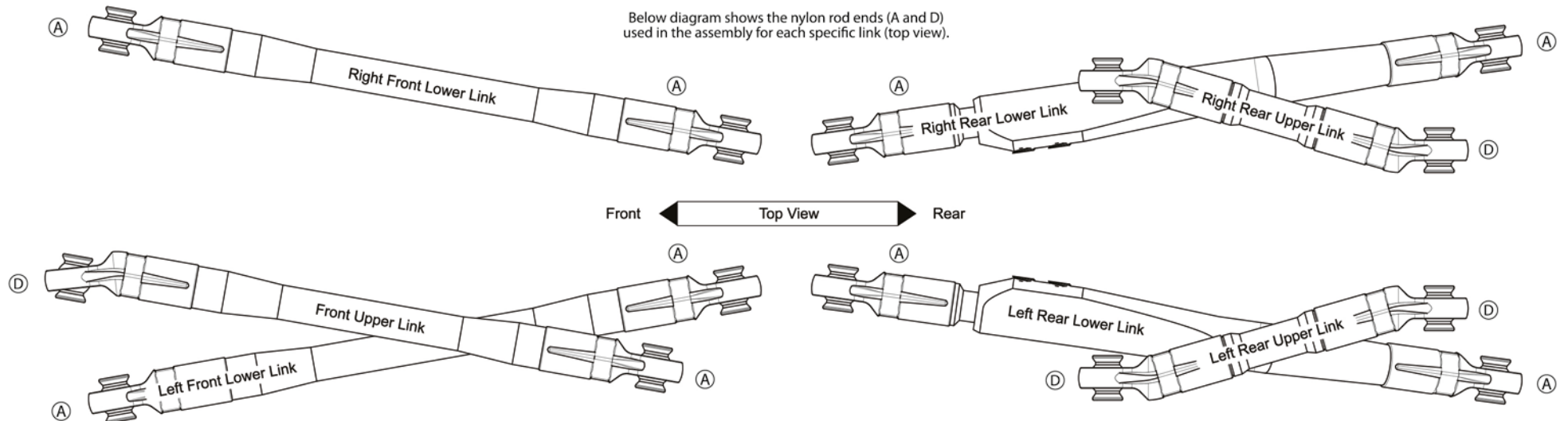

B LINKS / SHOCKS

 Nut M3 - Nylon x 3
 #BRASNUTM3

 M3x8 RS x 2
 #BRASBH3008

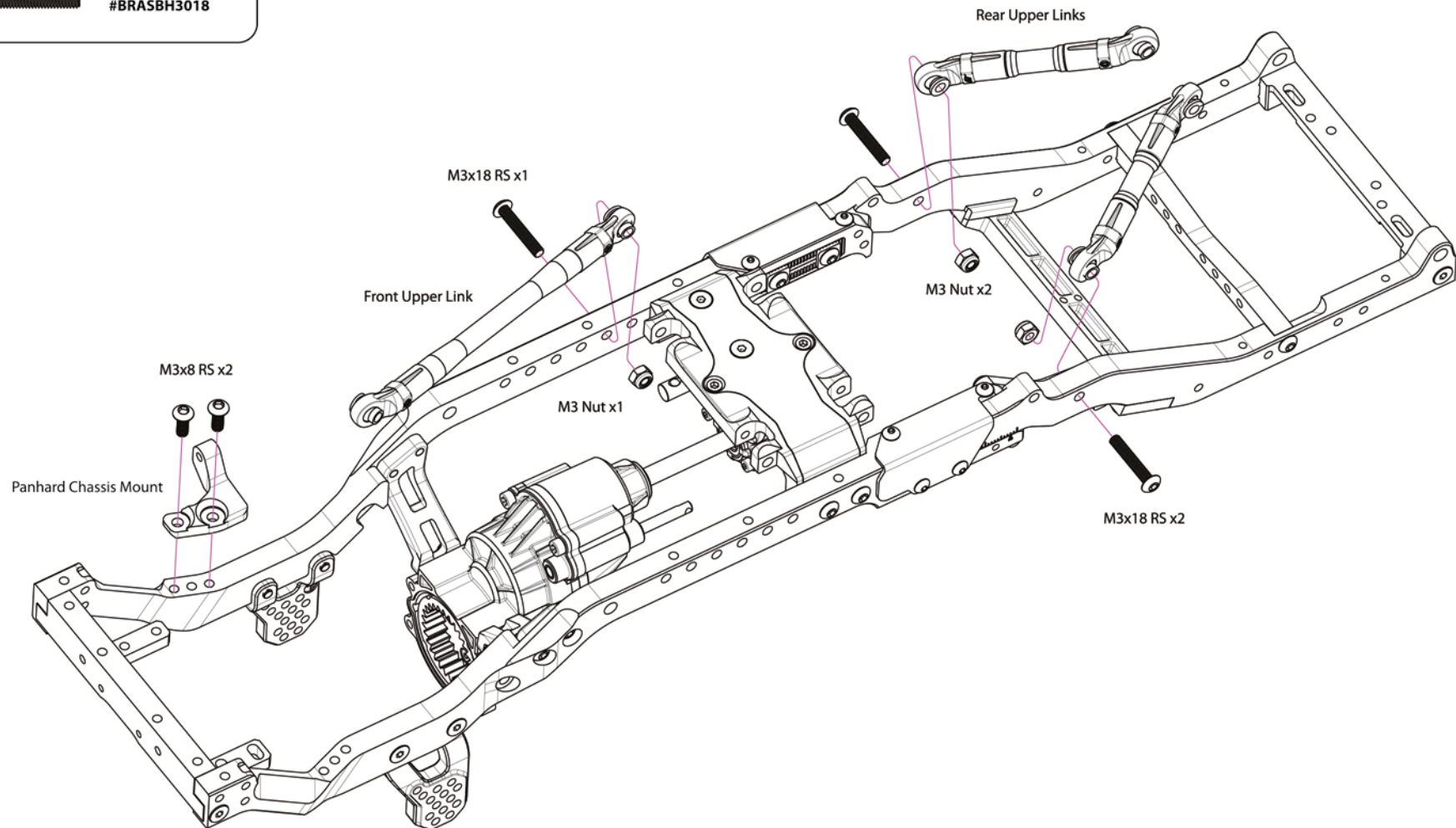
 M3x18 RS x 3
 #BRASBH3018

B LINKS / SHOCKS

M3x12 RS x1
#BRASBH3012

M3x16 RS x 4
#BRASBH3016

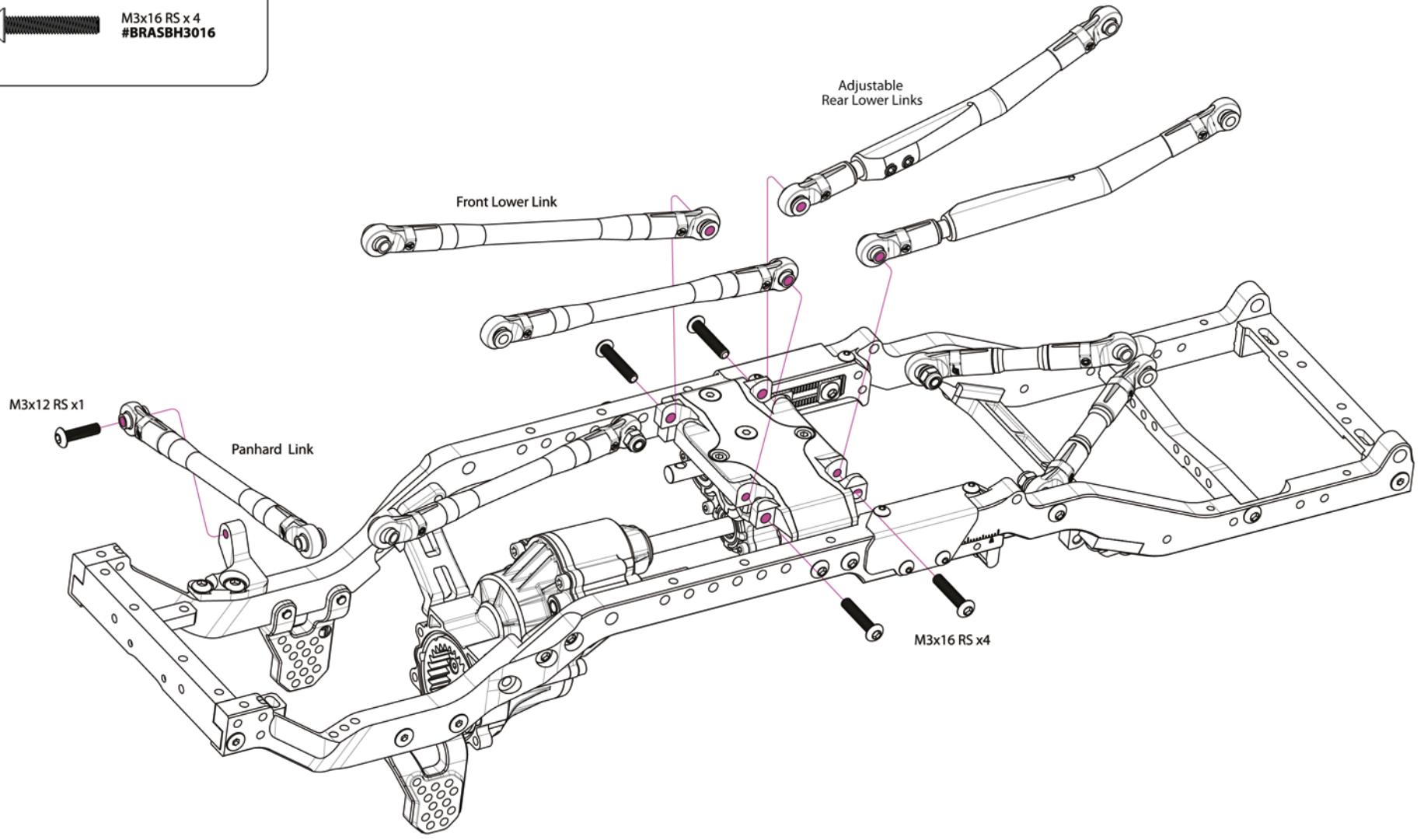

LINK SYSTEM

LINK SYSTEM

7 - FRONT AXLES

Parts Needed:

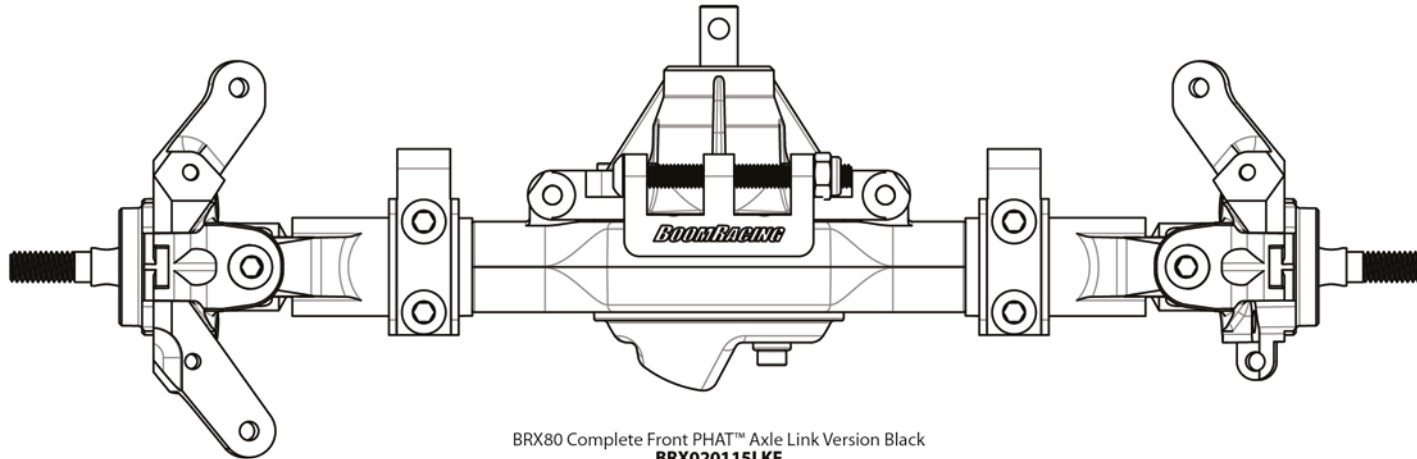

BRX80 Complete Front PHAT™ Axle Link Version Black
BRX020115LKF

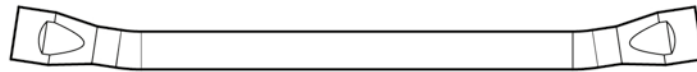

Stainless Steel Tie Rod x 1
#BRD8022A

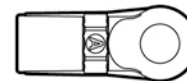

KUDU™
 Nylon Rod End (A)
 (Straight 18.5mm) x 2
#BRW750306A





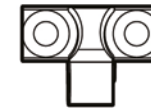

BADASS™
 Stainless Steel Pivot Ball x 2
#BRW750310





Panhard Axle Mount
#BRX020024

B LINKS / SHOCKS

-  M3x12 RS x 2
#BRASBH3012
-  M3x18 CSS x 2
#BRASFH3018
-  M4x16 SS x 2
#BRASST4016
-  D6x1.5 O-Ring x 2
#BRSORD6-15
-  D4x7x1 Stainless Steel Spacer x 2
#BRASSP471

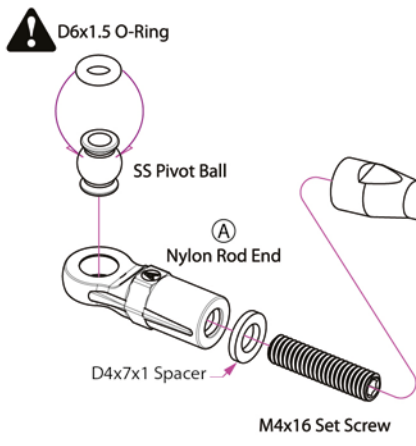
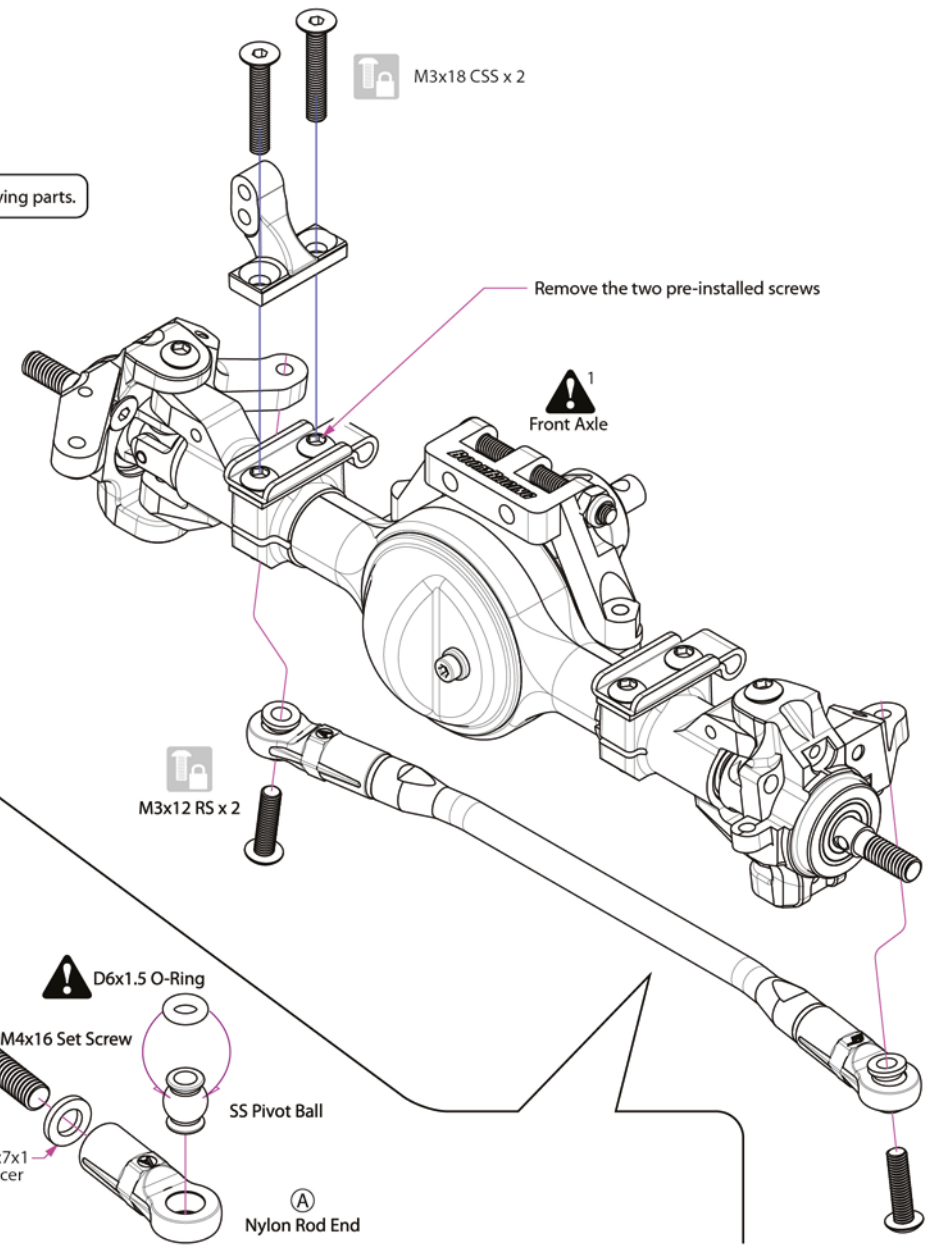
 ¹  Add thread lock to screws on moving parts.



 O-ring helps reduce tie rod from wobbling.

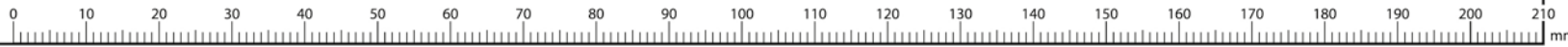
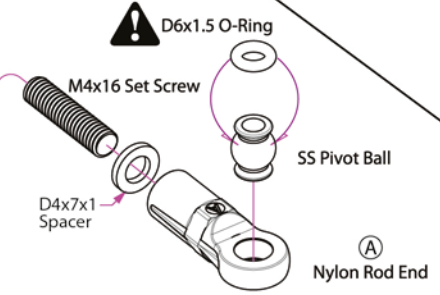

8 - SHOCKS

Parts Needed:



30WT Shock Oil 15ml x 1
(Available separately in 60ml)
#BRSHK030



Silicone Grease 10g x 1
#BRGRS10274-10



KUDU™ 70mm Medium (Green) Coilover Scale Shock Absorber x 2
#BRSH0070-SP

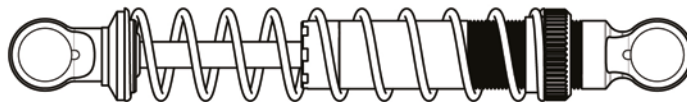

KUDU™ 80mm Medium (Green) Coilover Scale Shock Absorber x 2
#BRSH0080-SP



BADASS™
Stainless Steel Pivot Ball x 8
#BRW750310



Joint Retainer x 8
#BRSHJR

PIVOT BALL INSTALLATION & REMOVAL

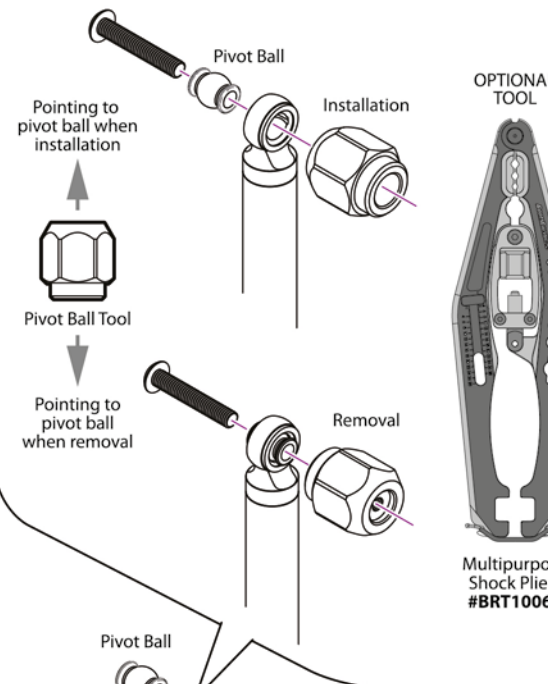

SHOCKS INSTALLATION & SETUP

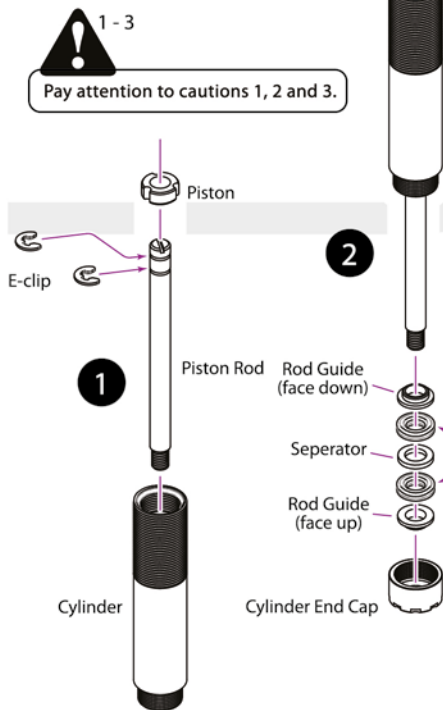

1-3
Pay attention to cautions 1, 2 and 3.

Use a slotted screwdriver (not provided) to secure piston rod into lower mount.

Oil Seal - apply Silicone Grease on each sealing ring for lubrication.

OPTIONAL
Shock Slime Grease 5g
#BRGRS09-5GB

For ultimate sealing performance, apply Shock Slime Grease instead.

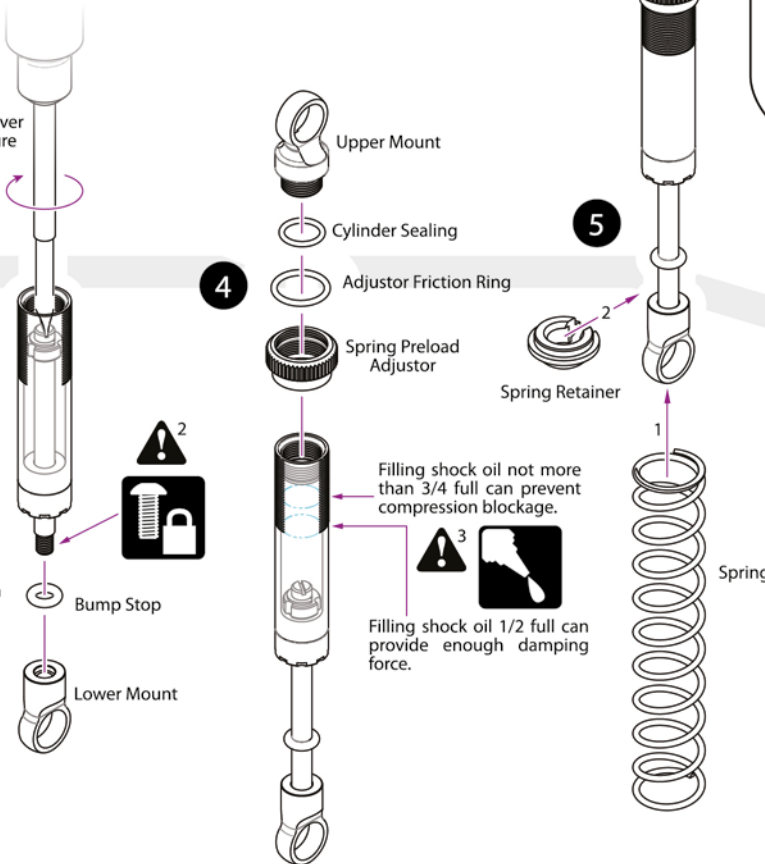

Filling shock oil not more than 3/4 full can prevent compression blockage.

Filling shock oil 1/2 full can provide enough damping force.

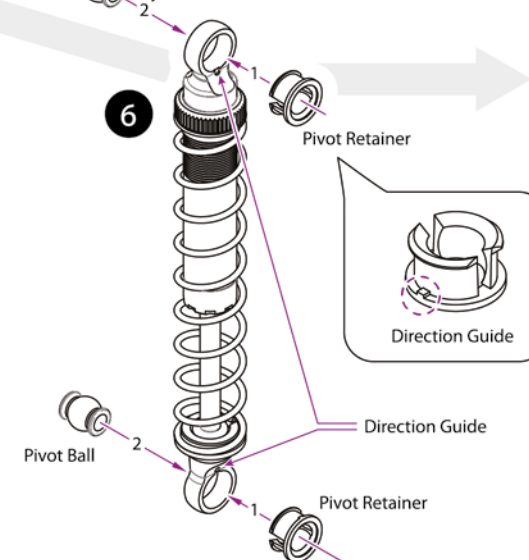

SHOCKS

SHOCKS

B LINKS / SHOCKS

-  3x6x3
Tapper Spacer x 2
#BRLC7041
-  M3 Nut - Nylon x 2
#BRASNUTM3
-  M3x12 RS x 1
#BRASBH3012
-  M3x16 RS x 2
#BRASBH3016
-  M3x26 RS x 2
#BRASBH3026



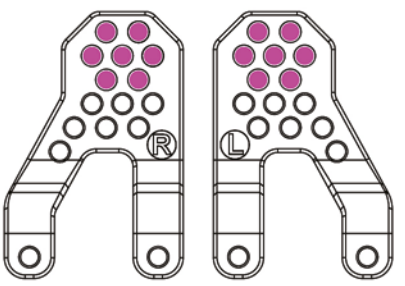
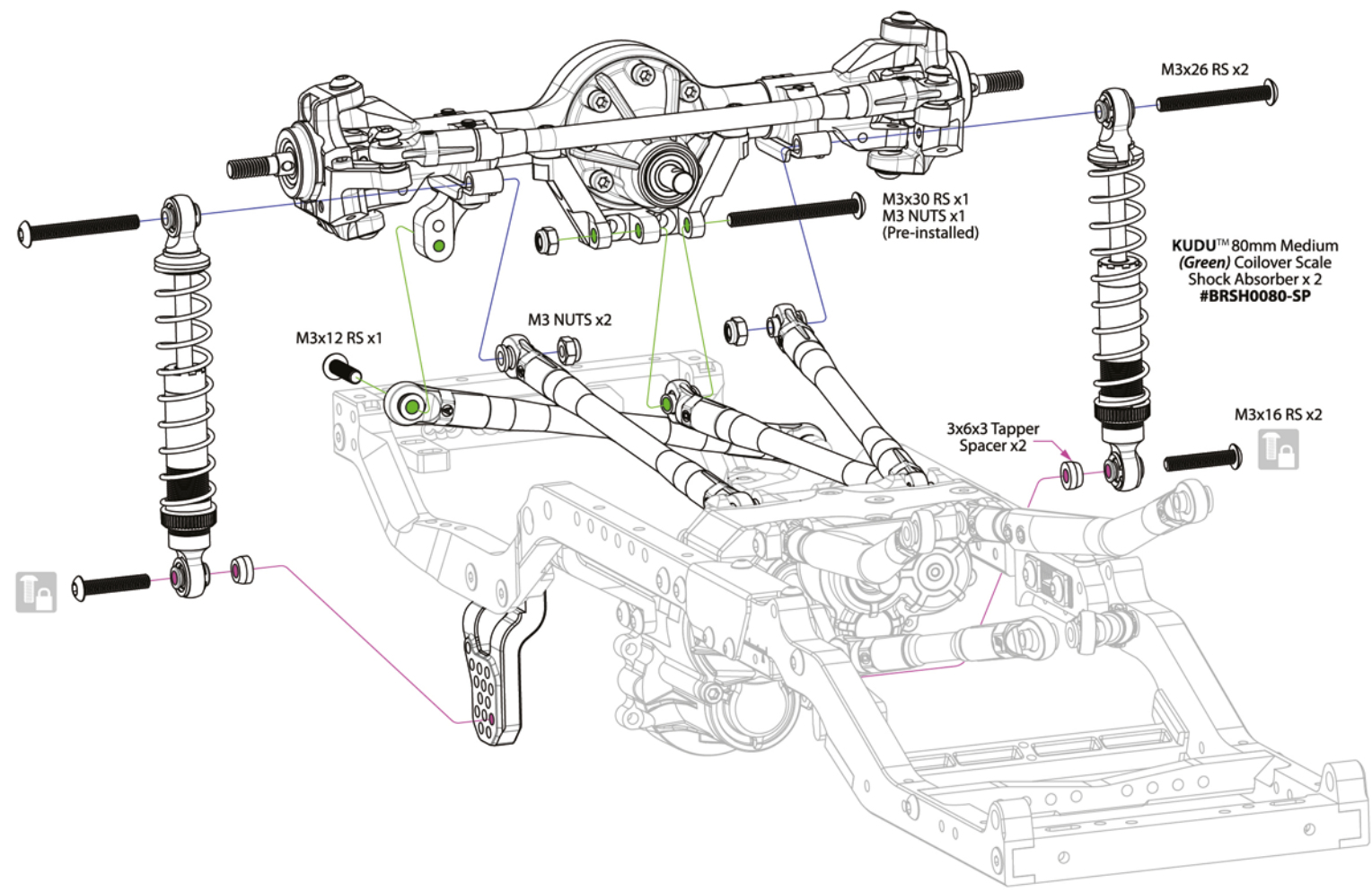

 Apply thread lock to all screws.
(Do not use red thread lock)

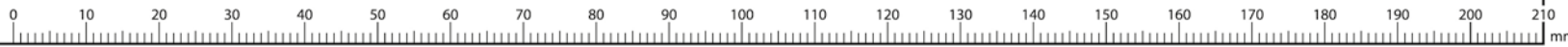

To increase ground clearance, only the highlighted holes can be used as optional shocks setup positions.



B LINKS / SHOCKS

-  M3x14 RS x 2
#BRASBH3014
-  M3x18 RS x 2
#BRASBH3018
-  M3x20 RS x 2
#BRASBH3020
-  3x6x5
Tapper Spacer x 2
#BRLC7040
-  3x6x6
Tapper Spacer x 2
#BRLC7042



Apply thread lock to all screws.
(Do not use red thread lock)

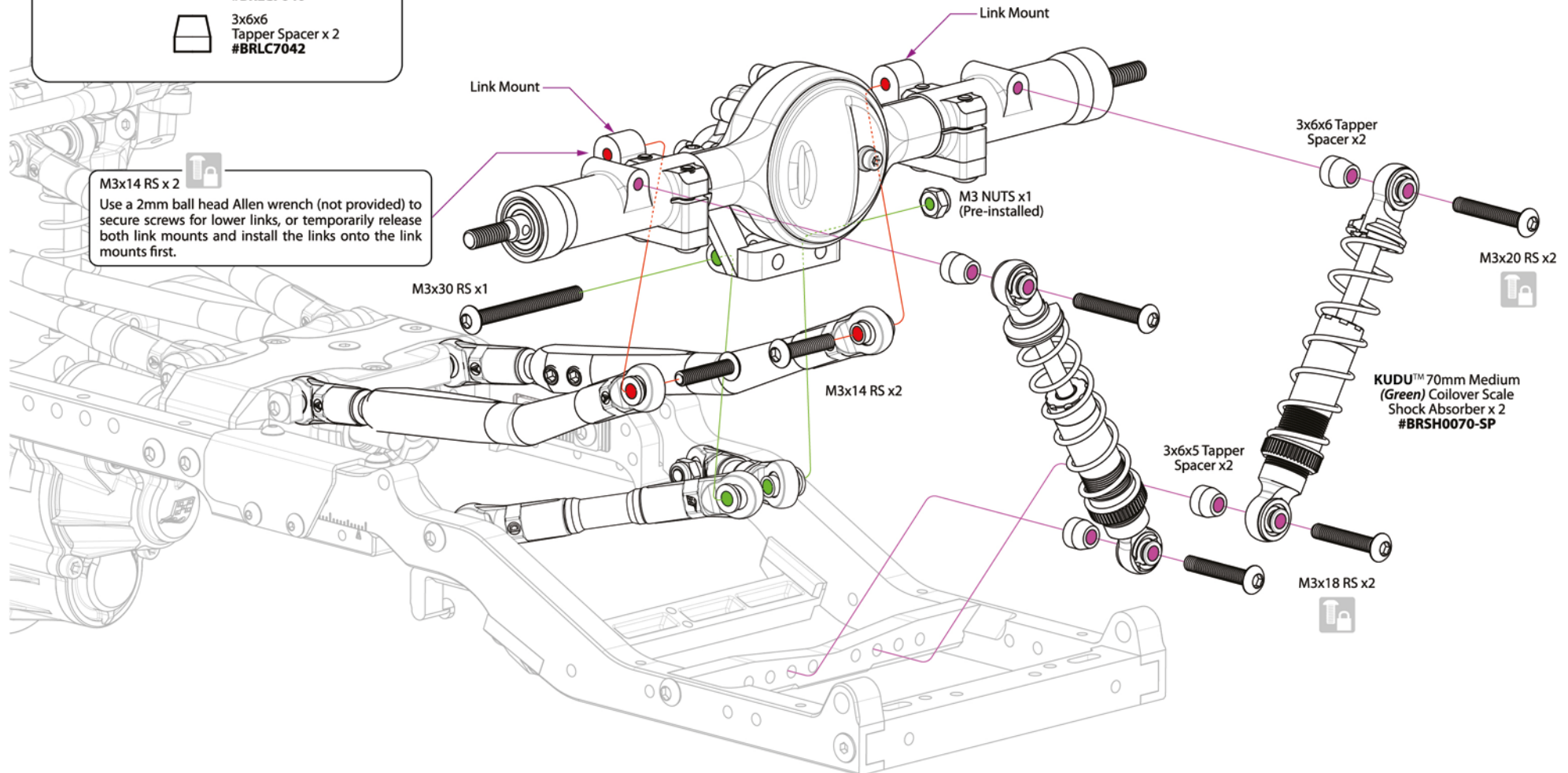

9 - DRIVE SHAFTS

Parts Needed:

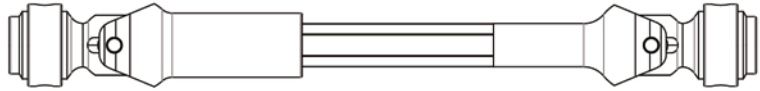

KUDU™ Heavy-Duty 80-90mm Steel CVD Center Drive Shaft x 1
#BRKD003-90

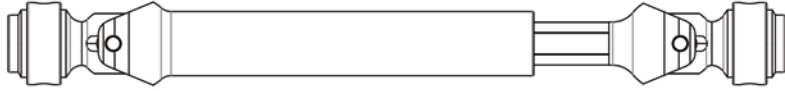

KUDU™ Heavy-Duty 84-99mm Steel CVD Center Drive Shaft x 1
#BRKD003-94

D GEARBOX / TRANSFER CASE



M3/2.2x11 SS x 4
#BRASST3022/DS

Align input shaft hole and drive shaft hole properly. Use the 1.5 Hex Key provided to help pull out the shaft if needed.

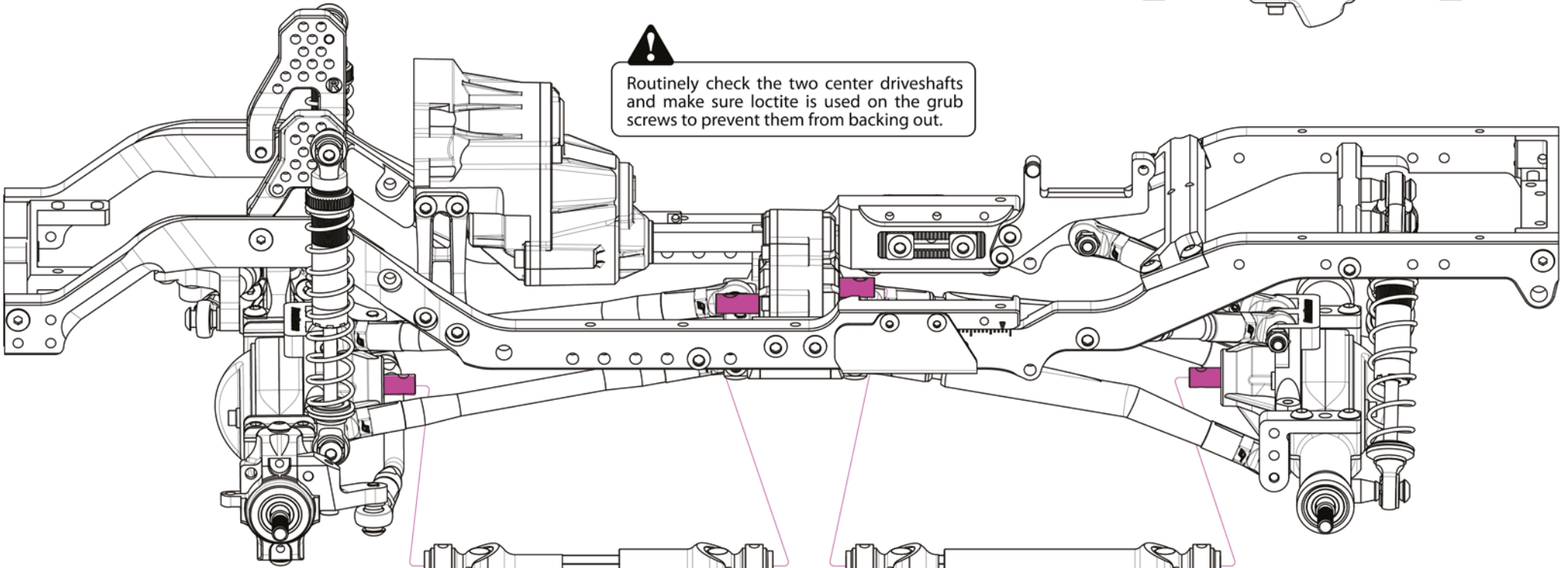

Routinely check the two center driveshafts and make sure loctite is used on the grub screws to prevent them from backing out.

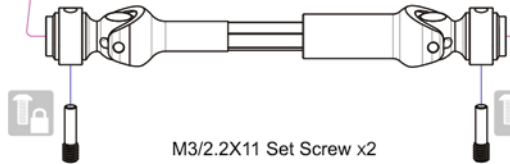

M3/2.2X11 Set Screw x2

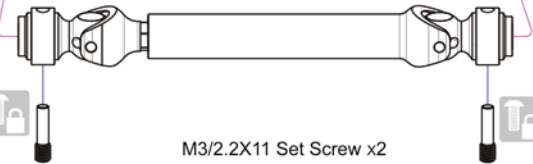

M3/2.2X11 Set Screw x2



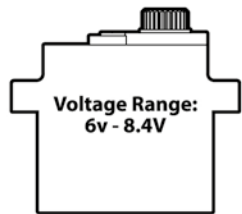
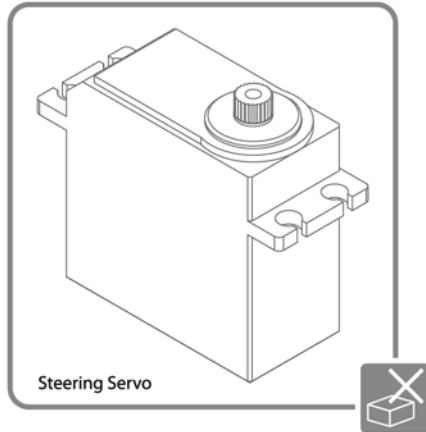

10 - SERVOS

Parts Needed:



JX Waterproof HV Mini Servo x 2
#JX/PDI-HV1151MG

F SERVOS

-  M3 Nut - Nylon x 2
#BRASNUTM3
-  M3x6 RS x 1
#BRASBH3006
-  M3x8 RS x 2
#BRASBH3008
-  M3x12 RS x 2
#BRASBH3012

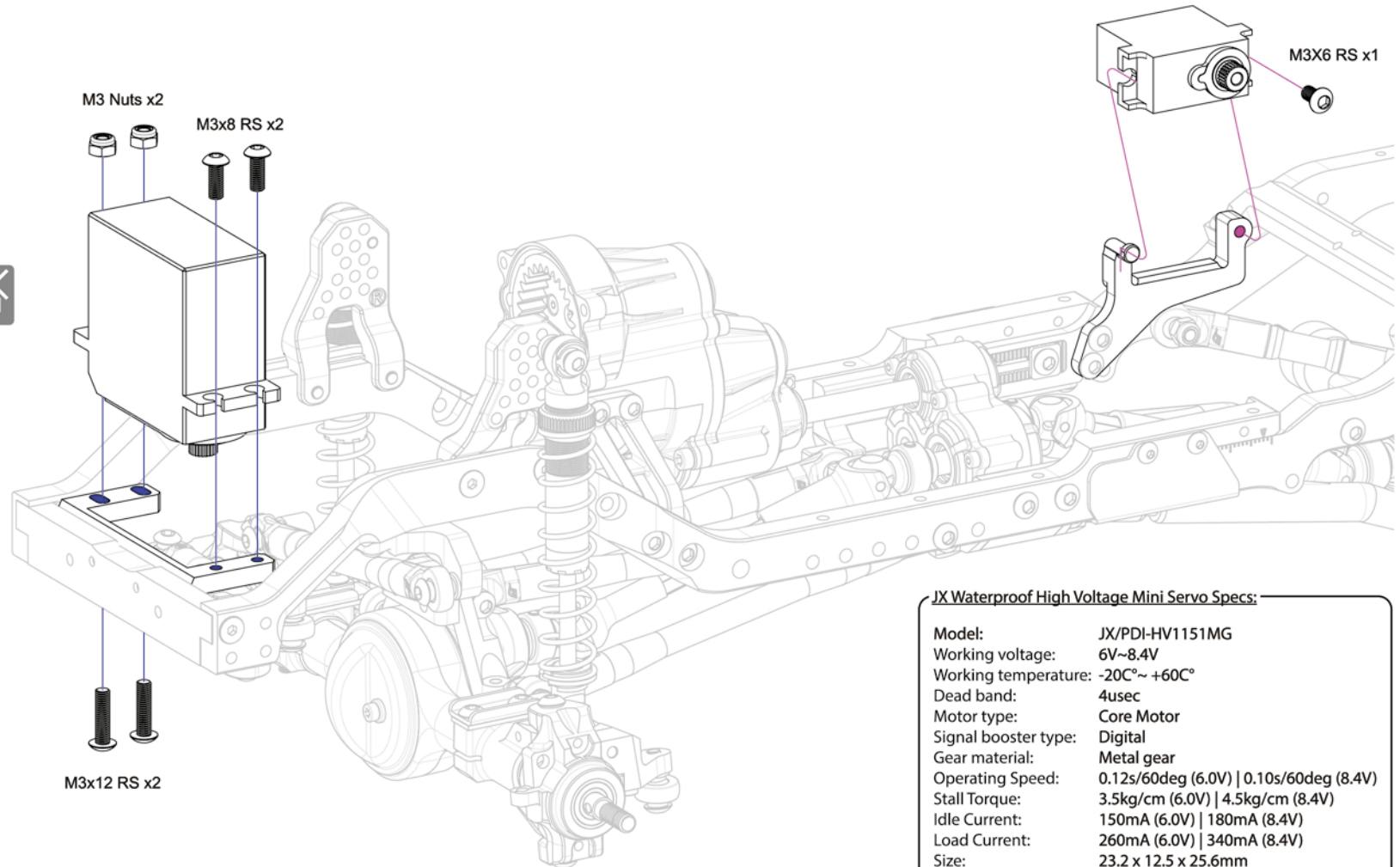

JX Waterproof High Voltage Mini Servo Specs:

Model:	JX/PDI-HV1151MG
Working voltage:	6V~8.4V
Working temperature:	-20C°~+60C°
Dead band:	4usec
Motor type:	Core Motor
Signal booster type:	Digital
Gear material:	Metal gear
Operating Speed:	0.12s/60deg (6.0V) 0.10s/60deg (8.4V)
Stall Torque:	3.5kg/cm (6.0V) 4.5kg/cm (8.4V)
Idle Current:	150mA (6.0V) 180mA (8.4V)
Load Current:	260mA (6.0V) 340mA (8.4V)
Size:	23.2 x 12.5 x 25.6mm
Weight:	15g
Tooth Count:	25
Wire length:	310mm JR plug
Black:	Negative
Red:	Positive
White:	Signal

Parts Needed:

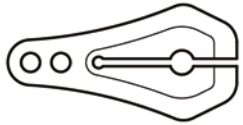

Low Profile Servo Horn 25T Black x 1
#BR955014BK

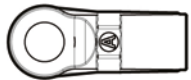

KUDU™ M4 Nylon Rod End (A)
(Straight 18.5mm) x 2
#BRW750306A



Fine Tunable Link - 55mm x 1
#BRLC7050

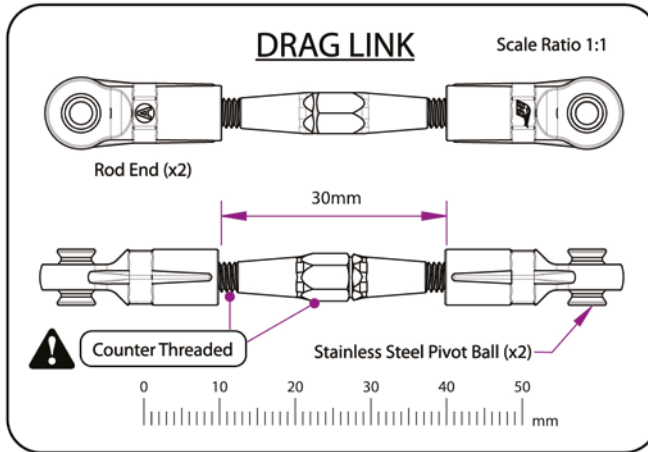

BADASS™
Stainless Steel Pivot Ball x 2
#BRW750310

B LINKS / SHOCKS



M3x12 RS x 2
#BRASBH3012

F SERVOS



M2x8 SC x 2
#BRASCH2008



M3x6 RS x 1
#BRASBH3006

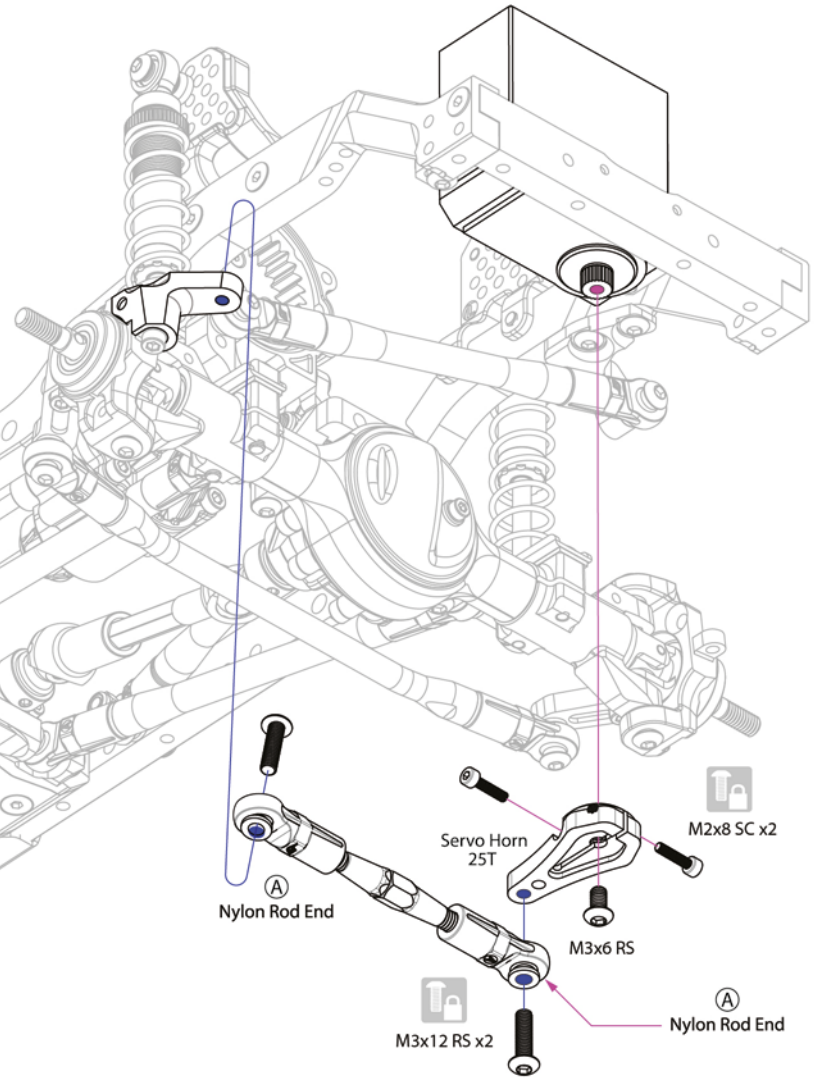

11 - SHIFT ROD



INSTALLING THE SHIFT ROD & CONFIGURING THE SHIFT SERVO

1. Attach the shift rod to the servo saver first, then connect it to the gearbox as illustrated in the diagram.
2. Temporarily connect the electronics. Choose a channel with a two-position switch and plug the shift servo into that channel.
3. With the servo connected, lower the EPA (End Point Adjustment) on both sides initially. Test the servo's rotation direction: counterclockwise shifts to first gear, and clockwise shifts to second gear (see diagram for reference).
4. Ensure the shift servo is set to the first gear position and the shift rod on the gearbox is fully extended outward. If it's not fully out (it should extend approximately 16mm), rotate the wheels slightly to adjust.
5. Once these steps are complete, secure the servo saver to the shift servo. Then, adjust the EPA settings to fine-tune the shifting, ensuring smooth transitions into both first and second gears.

* Note: Failure to setup the shift servo properly may cause the shift servo to malfunction or not shift into gear properly.

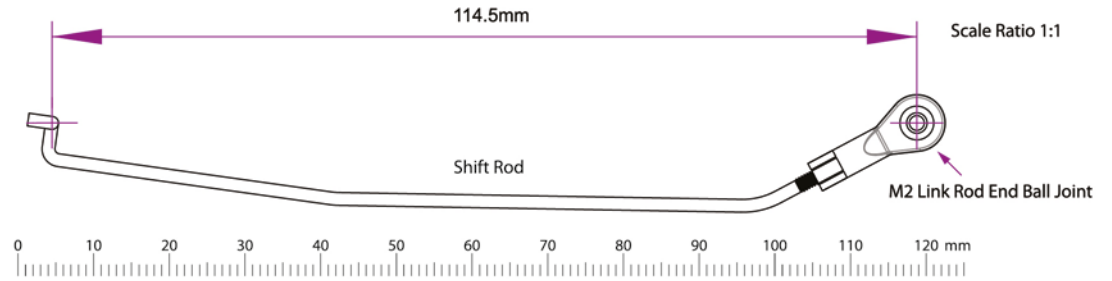

Parts Needed:

F SERVOS

	#BRLC7049 Follower Horn A x 1
	Spring Horn A x 1
	Initiator Horn A x 1
	#BRASBH3006 M3x6 RS x 1
	#BRASCH2008 M2x8 SC x 1

D2 Ball & Rod End x 1
#BRQ90351

AWB Switch Lever
#BRLC70207

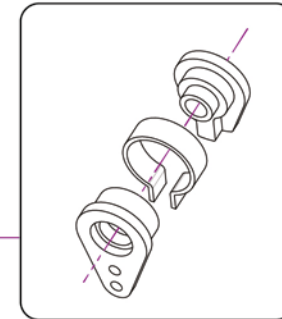
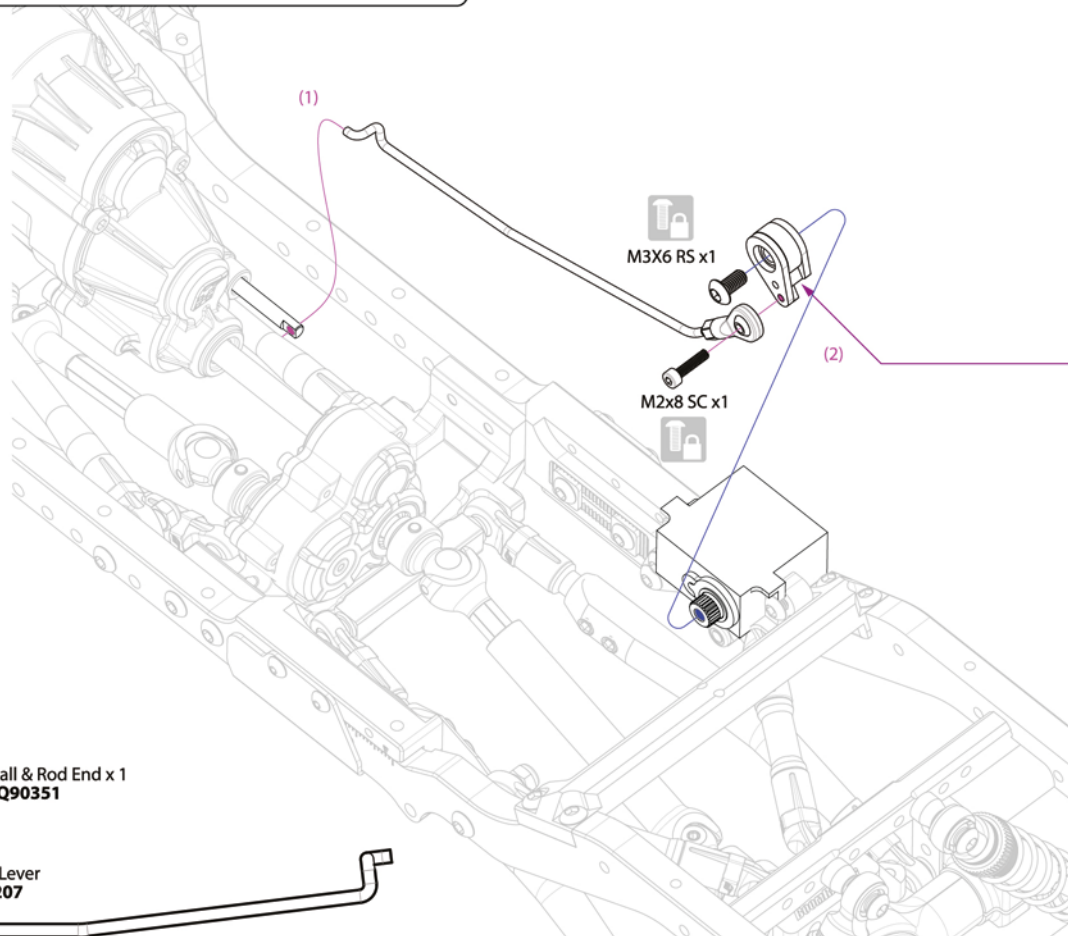
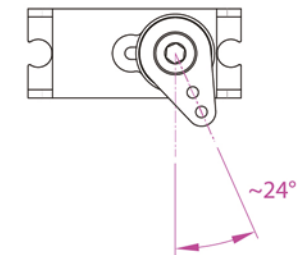

DIAGRAM 12.1

Servo horn position for the 1st gear.



12 - MOTOR

Parts Needed:

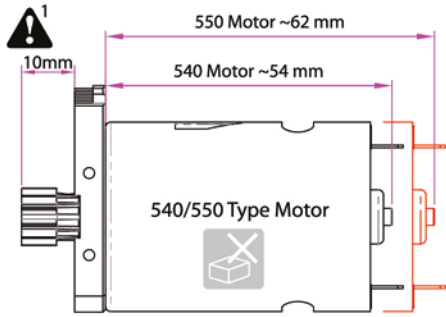

540/550 type motors can be used on BRX01-AWB.

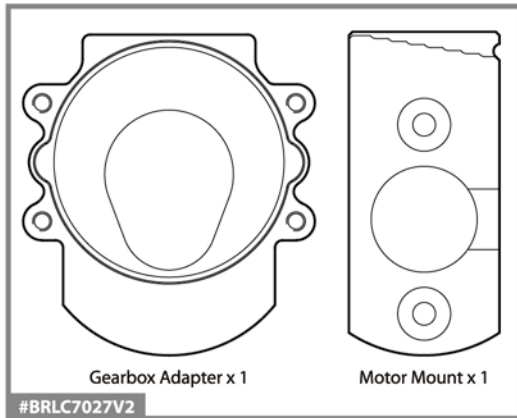

D GEARBOX / TRANSFER CASE

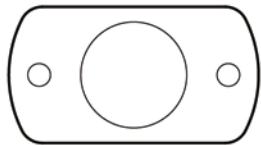

Motor Spacer x 1
#BRLC7032



M3x8 SC x 2
#BRASCH3008

M2.5x8 SC x 8
#BRASCH2508



12T 32P Pinion Gear
#BRPG3212-3

2
Use the corresponding number of the pinion gear tooth (**1**) on the Motor Mount to get the best gear mesh. Adjust the Motor Mount up and down until both surface indicators (**2**) are leveled (align at index 12 for the 12T pinion gear supplied as pictured).

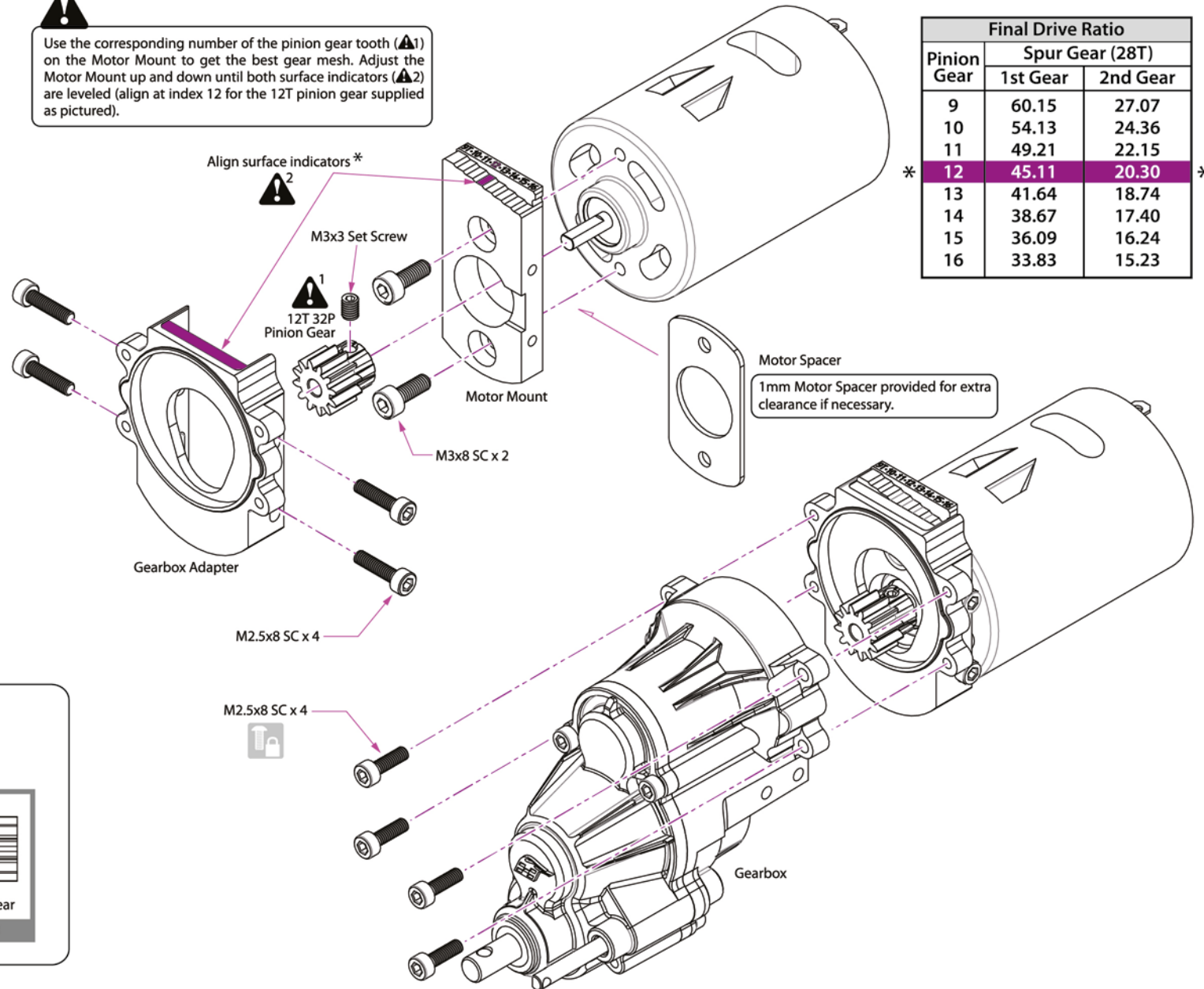

Pinion Gear	Final Drive Ratio	
	Spur Gear (28T)	
	1st Gear	2nd Gear
9	60.15	27.07
10	54.13	24.36
11	49.21	22.15
* 12	45.11	20.30
13	41.64	18.74
14	38.67	17.40
15	36.09	16.24
16	33.83	15.23

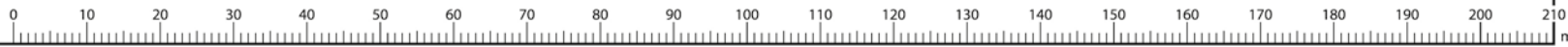

13 - RECEIVER BOX & ELECTRONICS INSTALLATION

Parts Needed:

#BRLC70221



Stainless Steel Sealing Plate x 1



Silicone Port x 1

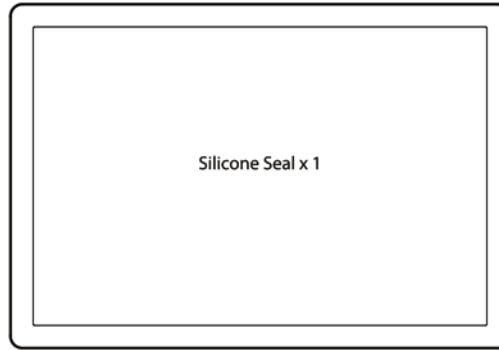

Silicone Seal x 1

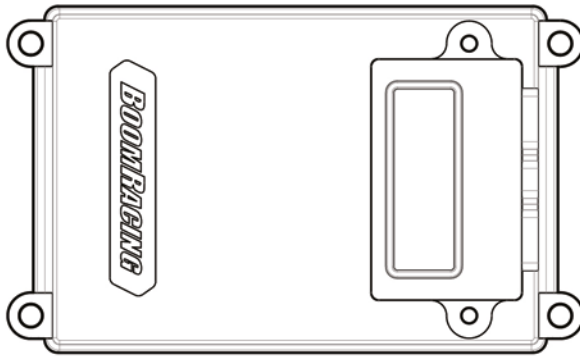

Receiver Box Cover x 1

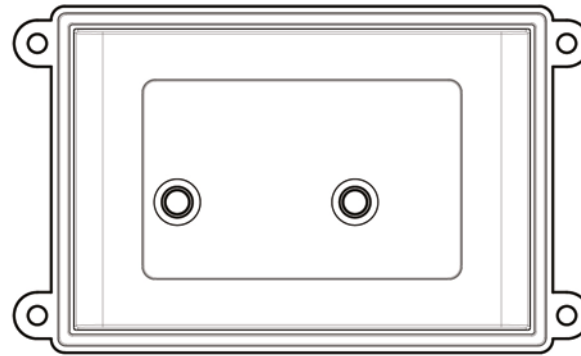

Receiver Box x 1

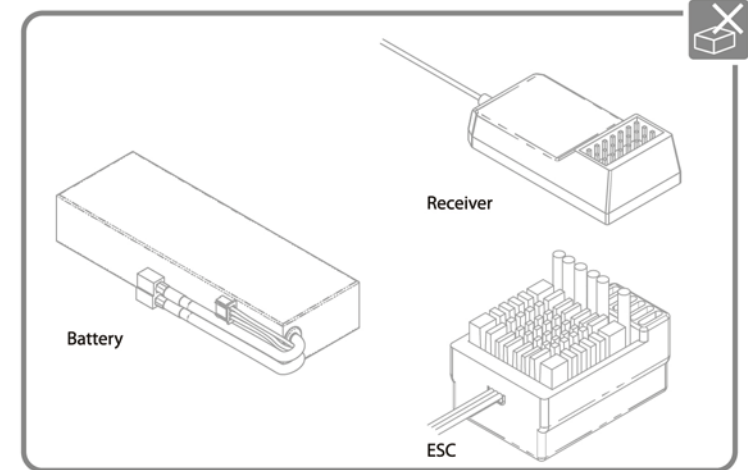

E RECEIVER BOX



M3x8 CSS x 2
#BRASFH3008



Apply thread lock to all screws.
(Do not use red thread lock)

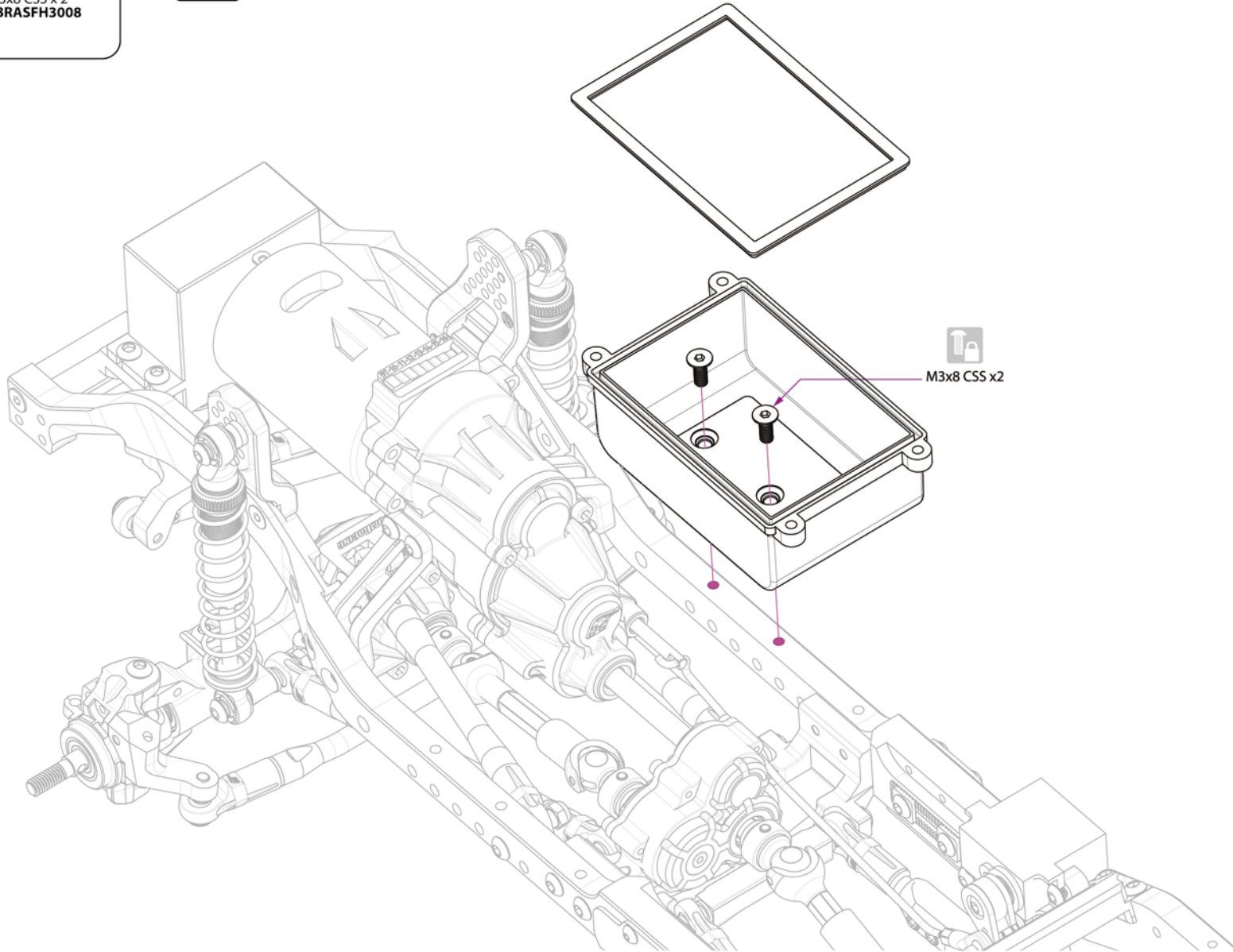

E RECEIVER BOX

 M2.5x6 RS x 2
 #BRASBH2506

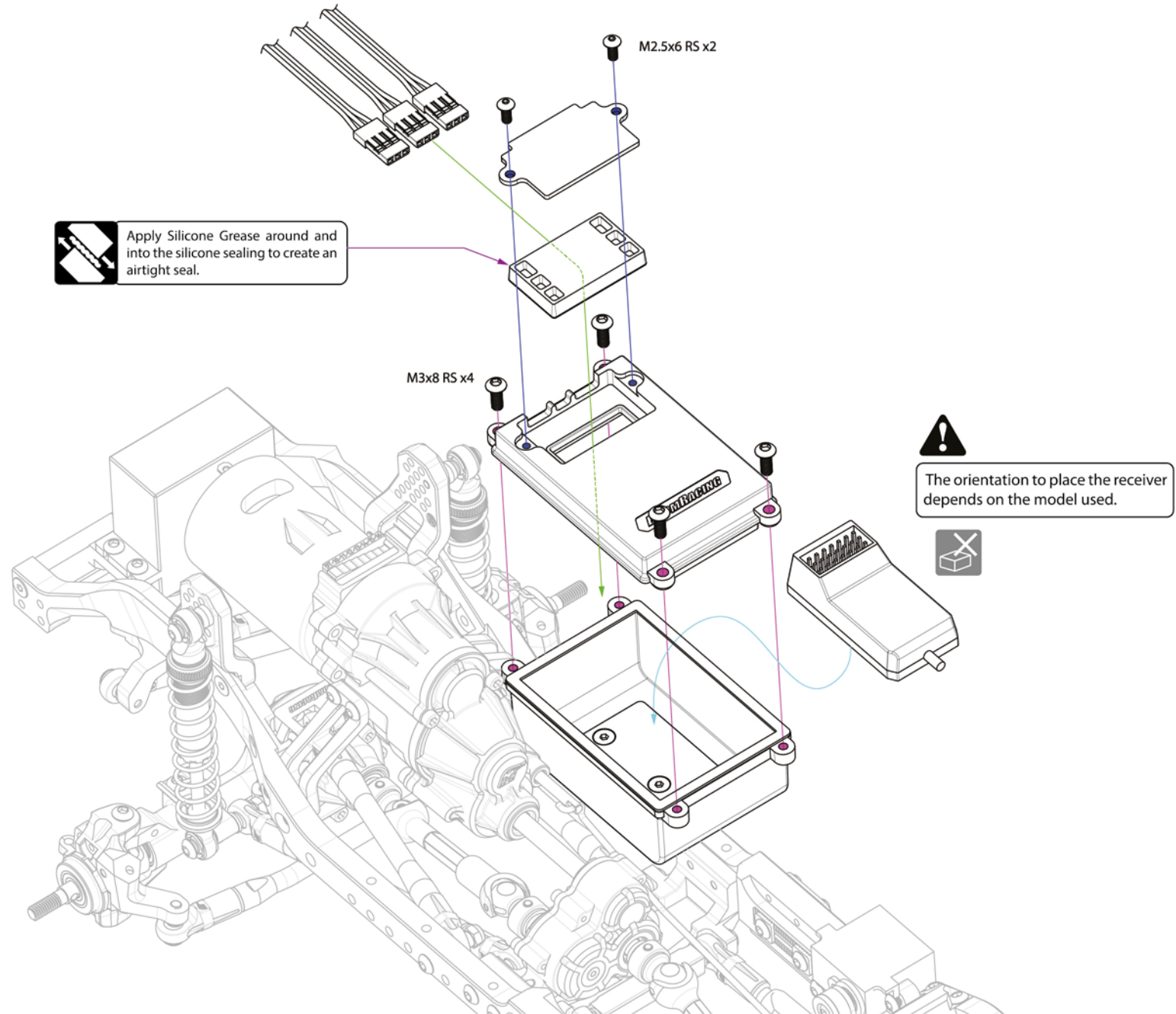

 M3x8 RS x 4
 #BRASBH3008

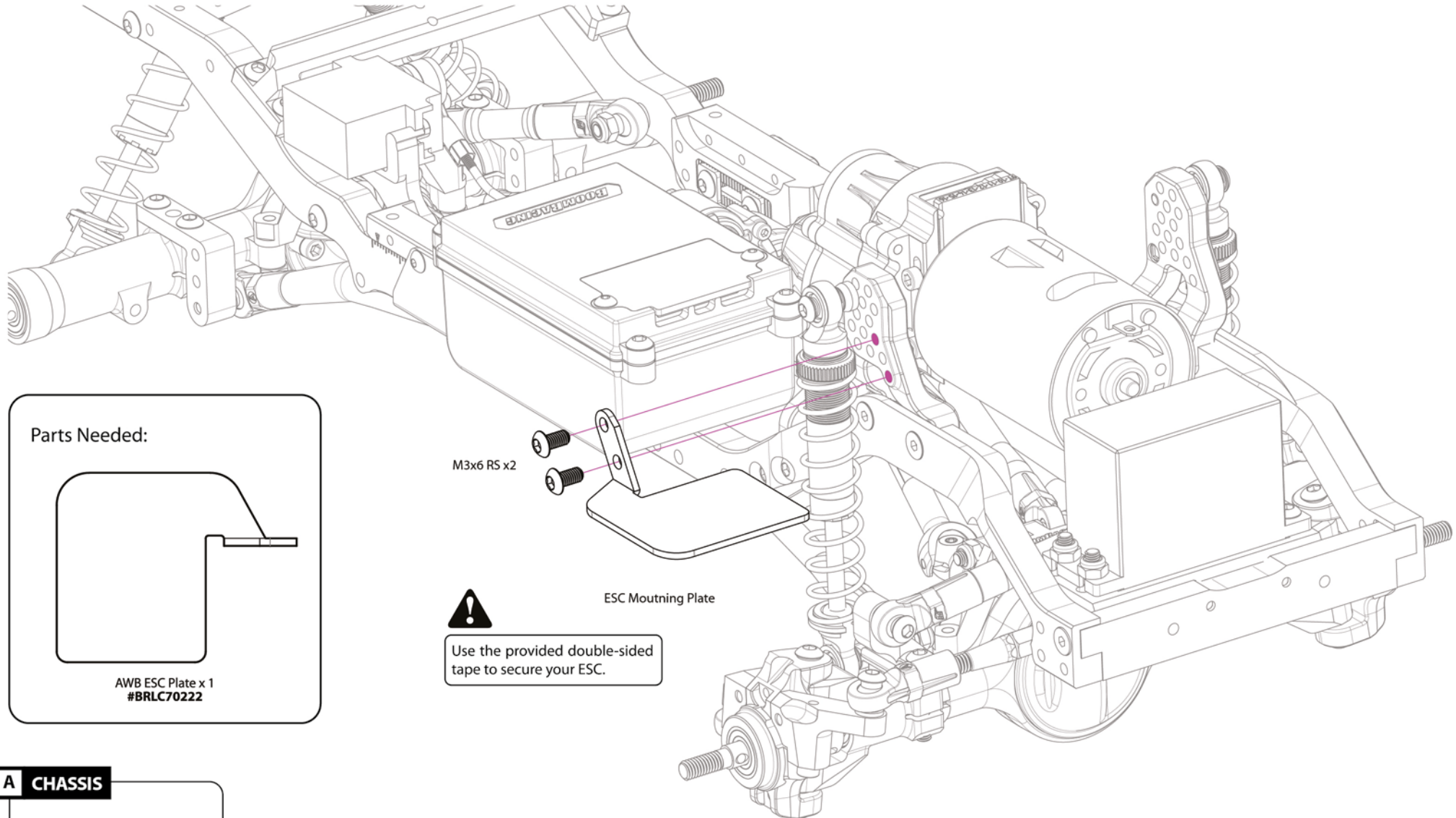
 Apply Silicone Grease around and into the silicone sealing to create an airtight seal.

14 - ESC MOUNT

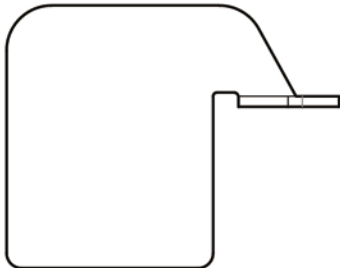

Parts Needed:



AWB ESC Plate x 1
#BRLC70222

M3x6 RS x2



ESC Mouting Plate

Use the provided double-sided tape to secure your ESC.

A CHASSIS



M3x6 RS x 2
#BRASBH3006

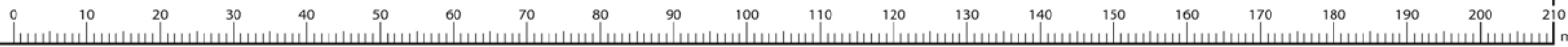

15 - WHEELS & TIRES

Parts Needed:

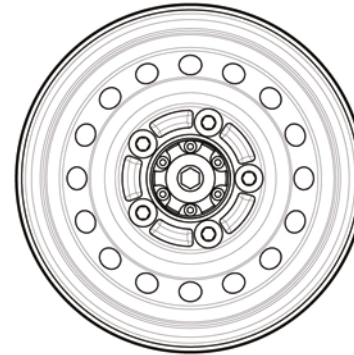

1.55" 16-Hole Classic Steelie Reversible
 Beadlock Wheels (Front)
 w/ XT504 Hubs x 2 (Gun Metal)
#BRW780955FGM

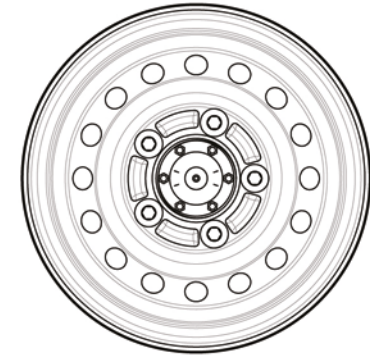

1.55" 16-Hole Classic Steelie Reversible
 Beadlock Wheels (Rear)
 w/ XT504 Hubs x 2 (Gun Metal)
#BRW780955RGM

C WHEELS



Wheel Hex x 4
#BRLC7056



M4 Nut - Nyloc x 4
#BRASNUTM4



2x10mm Pin x 4
#BRASPIN210



M3x3 SS x 4
#BRASST3003

(Wheels, tires, and inserts not included in Builder's Kit BR8014)

(Wheels, tires, and inserts not included in Builder's Kit BR8014)

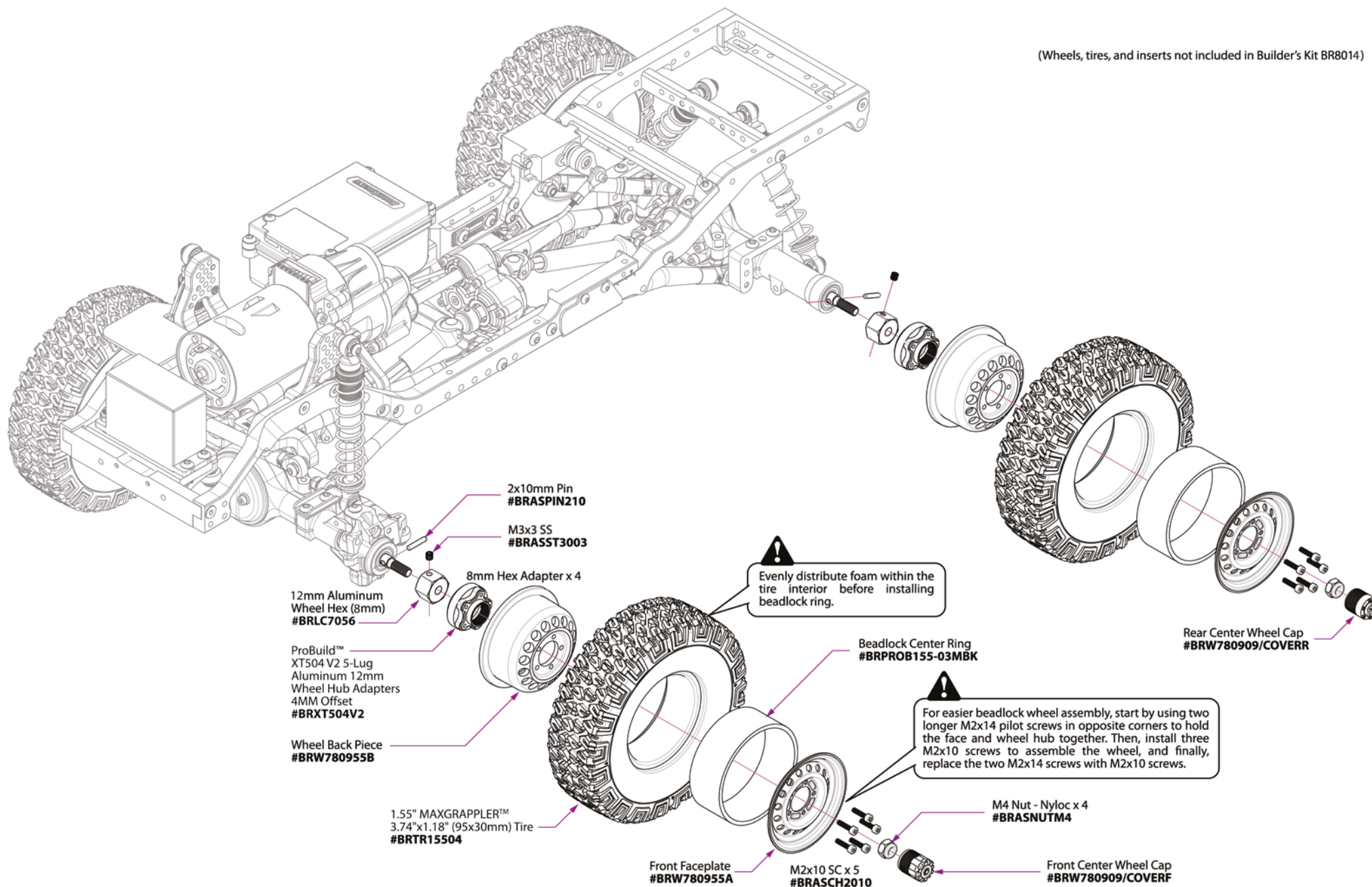

ADJUSTABLE WHEELBASE PARTS LIST (LINKED VERSION)

AWB Standard Rear Rails

Wheelbase 265-285mm / 10.4" - 11.2"

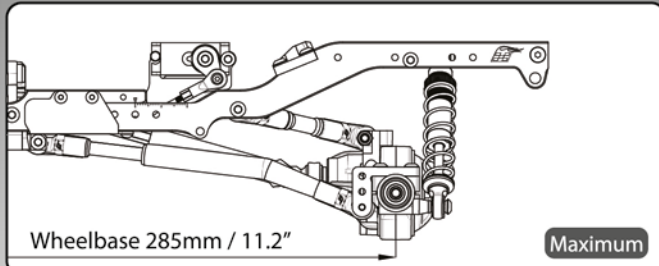
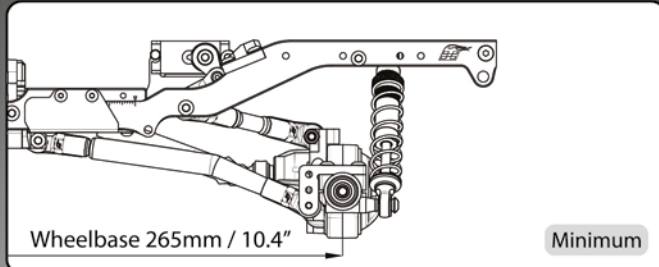

Recommended parts:

Rear Rails:
 AWB Standard Rear Rails (Left & Right) **#BRLC70212**

Rear Lower Links:
 42mm Rear Lower Link Spline Shaft (2) **#BRLC70229**

Rear Driveshaft:
 Wheelbase 265-285 / 10.4"-11.2" **#BRKD003-94**

AWB XL Rear Rails

Wheelbase 285-305mm / 11.2" - 12.0"

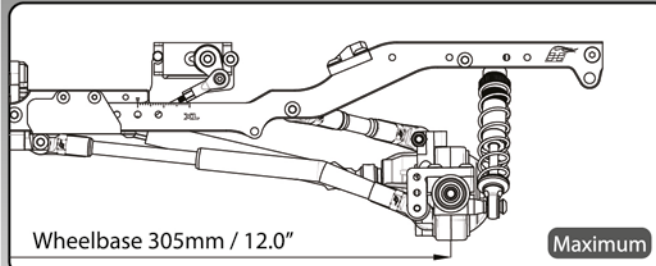
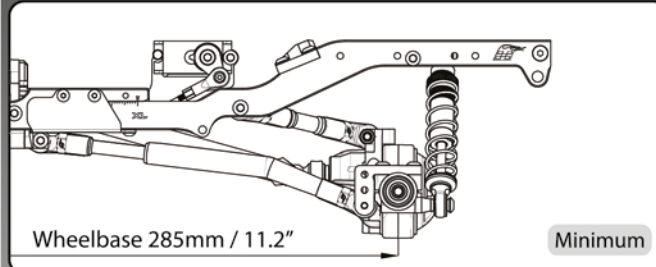

Recommended parts:

Rear Rails:
 AWB XL Rear Rails (Left & Right) **#BRLC70213**

Rear Lower Links:
 62mm Stainless Steel Rear Lower Link Spline Shaft (2)
#BRLC70229-XL

Rear Driveshaft:
 Wheelbase 285-325 / 11.2"-12.8" **#BRKD003-116**

AWB 2XL Rear Rails

Wheelbase 305-325mm / 12.0" - 12.8"

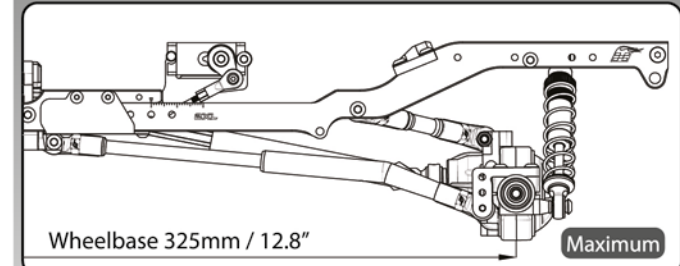
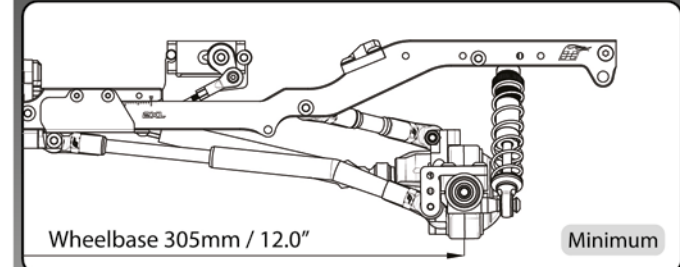

Recommended parts:

Rear Rails:
 AWB 2XL Rear Rails (Left & Right) **#BRLC70235**

Rear Lower Links:
 82mm Stainless Steel Rear Lower Link Spline Shaft (2)
#BRLC70229-2XL

Rear Driveshaft:
 Wheelbase 285-325 / 11.2"-12.8" **#BRKD003-116**

PRE-ASSEMBLED AXLE

Front Diff Cover Release Method In Case Assembly Is Tight.

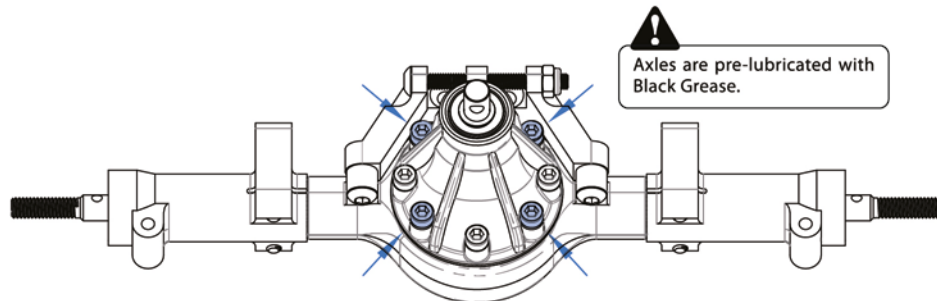

Step 1 - Loosen four M2.5x16mm socket screws indicated making the screw cap 3 mm apart from the case.

Step 2 - Hammer those screw slightly via screwdriver to release the front diff cover.

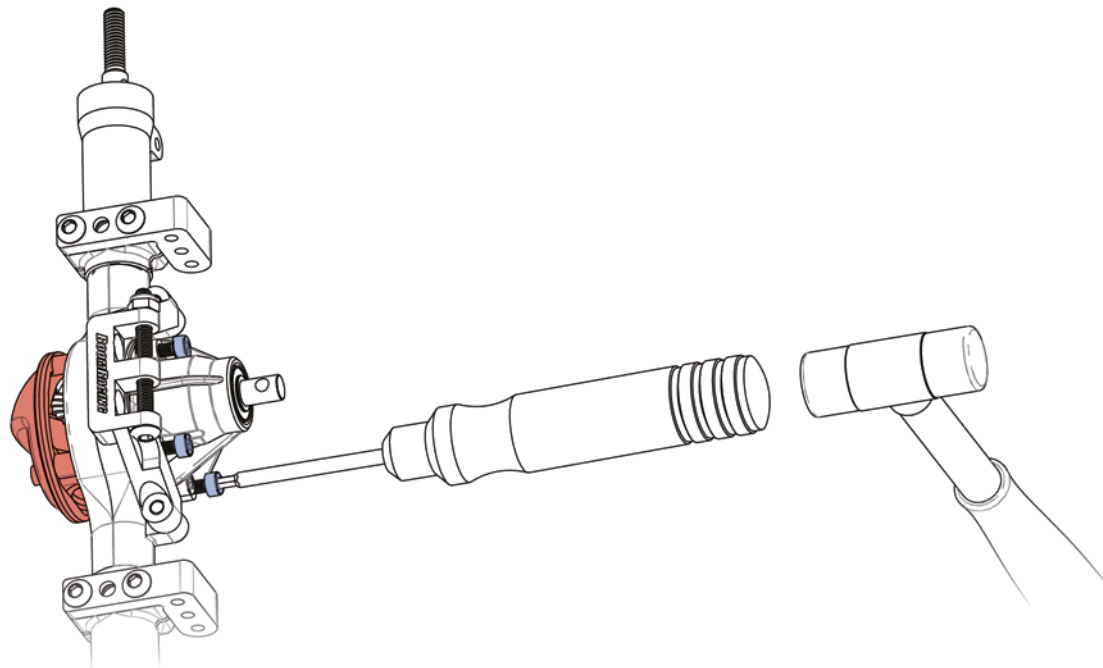

The Third Member Release Method When Assembly Is Tight.

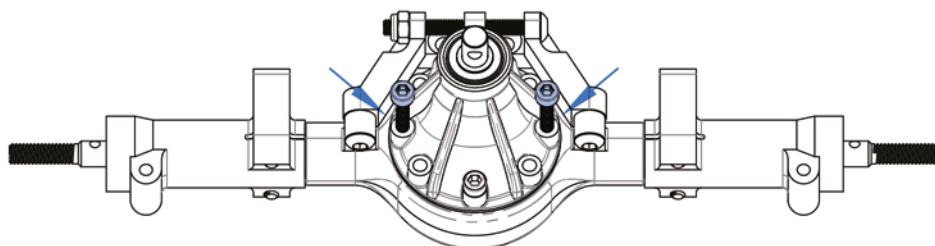



Step 1 - Remove all M2.5x16mm and two M2.5x5mm socket screws

Step 2 - Install two M2.5x16mm socket screws into both left and right screw holes as indicated

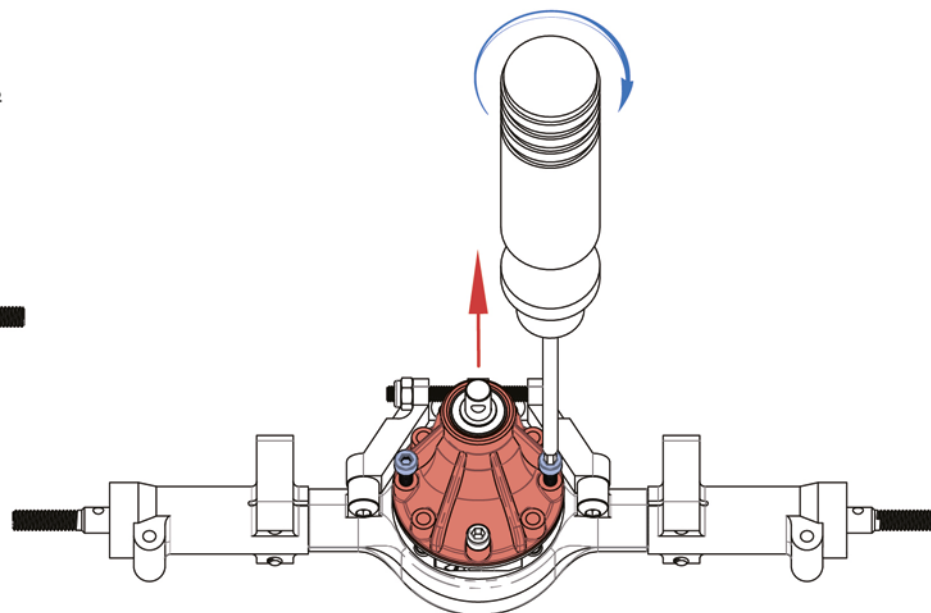
Step 3 - Lightly torque the screws until the third member is released



PRE-ASSEMBLED FRONT AXLE

  Apply a generous amount of Black Grease on all movable contact surfaces including gears, spacers, shafts and bearings.

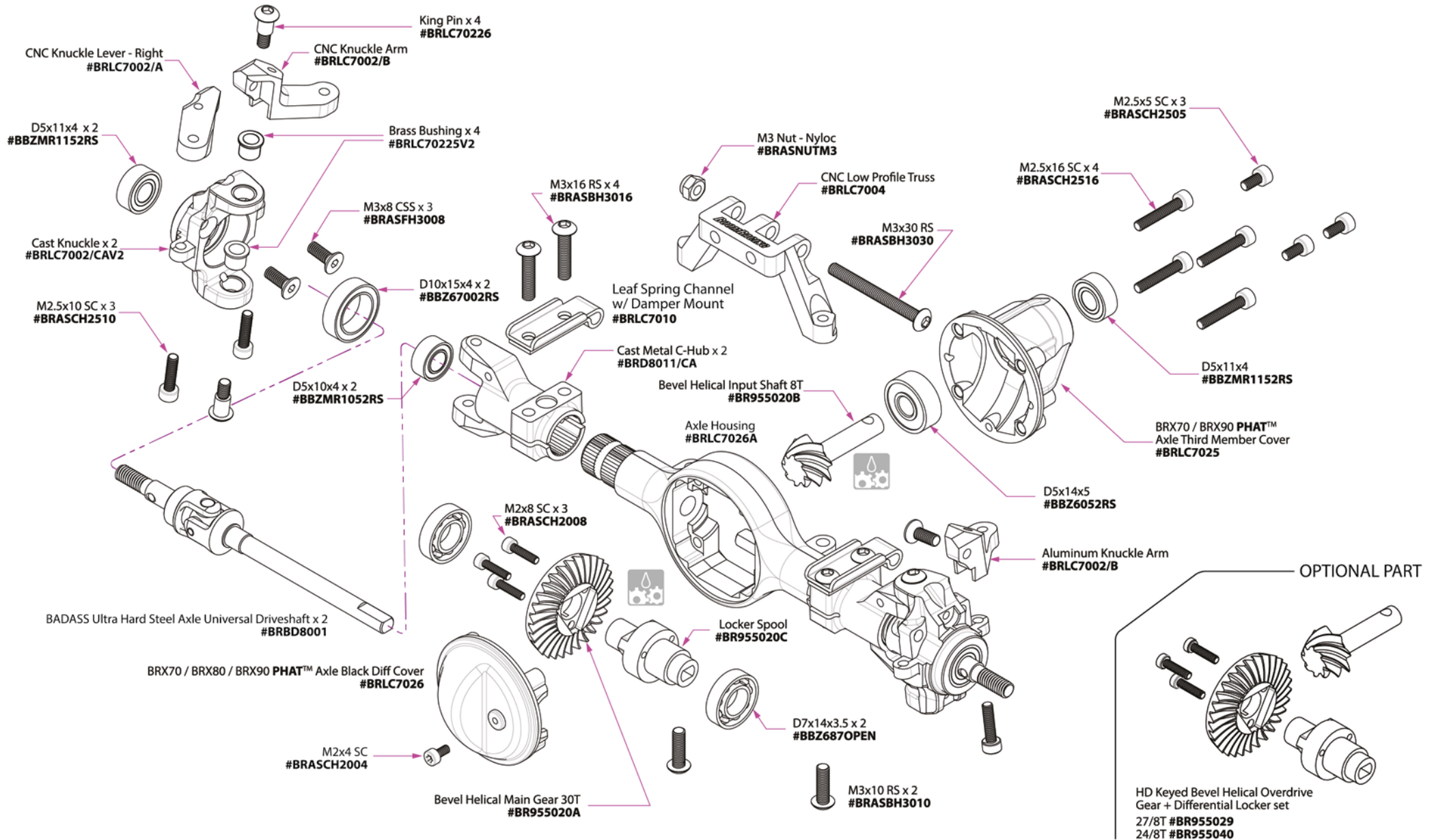

PRE-ASSEMBLED REAR AXLE

  Apply a generous amount of Black Grease on all movable contact surfaces including gears, spacers, shafts and bearings.

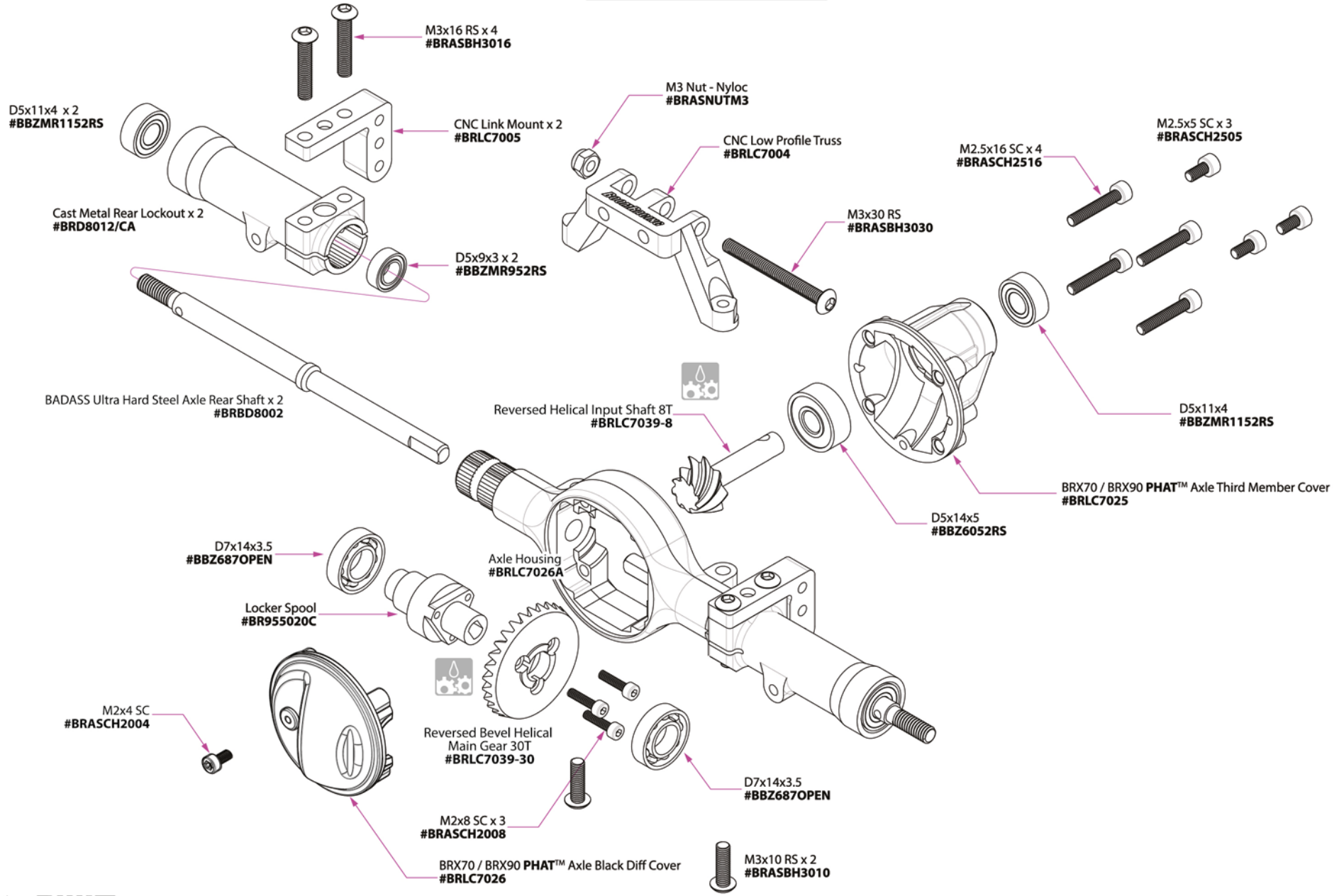

PRE-ASSEMBLED PARTS

PRE-ASSEMBLED PARTS

COMPLETE

Illustration for reference only.
(Wheels, tires, and inserts not included in Builder's Kit BR8014)

PARTS LIST

Part #	Description	Part #	Description
BBZ6052RS	High Performance Rubber Sealed Ball Bearing 5x14x5mm (1)	BRBD8002	BADASS™ Ultra Hard Steel Axle Rear Shaft (2pcs) for BRX80 PHAT™ Axle BRD8023
BBZ67002RS	High Performance Rubber Sealed Ball Bearing 10x15x4mm (1)	BRD8011/CA	Cast Metal C-hub (2)
BBZ687OPEN	Open Ball Bearing 7x14x3.5mm (1)	BRD8012/CA	Cast Metal Rear Lockout for BRX80 PHAT™ Axle
BBZMR1042RS	High Performance Rubber Sealed Ball Bearing 4x10x4 Ball Bearing (1)	BRD8022A	Stainless Steel Tie Rod (1) for BRX80 PHAT™ Axle
BBZMR1052RS	High Performance Rubber Sealed Ball Bearing 5x10x4mm (1)	BRGRS10274-10	SW Silicone Grease 10g (1)
BBZMR115RS	High Performance Rubber Sealed Ball Bearing 5x11x4 Ball Bearing (7)	BRGRS1055-10	Black Graphite Grease 10g (1)
BBZMR1172RS	High Performance Rubber Sealed Ball Bearing 7x11x3 Ball Bearing (1)	BRGRS242	242 Thread Lock 2g (1)
BBZMR952RS	High Performance Rubber Sealed Ball Bearing 5x9x3mm (1)	BRKD003-90	KUDU™ Heavy-Duty 80-90mm Steel CVD Center Drive Shaft (1)
BR955014BK	Aluminum Low Profile Servo Horn 25T Black	BRKD003-94	KUDU™ Heavy-Duty 84-99mm Steel CVD Center Drive Shaft (1)
BR955020	Heavy Duty Keyed Bevel Helical Gear 30/8T + Differential Locker Spool Set	BRLC7002/A	Aluminum Knuckle Lever (High Clearance) Right for BRX70/BRX80/BRX90 PHAT™ Axle Knuckle (1)
BRASBH2506	M2.5x6mm Round Head 12.9 Grade Nickel Plated Screws (10)	BRLC7002/B	Aluminum Knuckle Arm (Low Profile) for BRX70/BRX80/BRX90 PHAT™ & AR44 Knuckle (2)
BRASBH3006	M3x6mm Round Head 12.9 Grade Nickel Plated Screws (10)	BRLC7002/CAV2	Cast Metal Knuckle V2 for BRX70/BRX80/BRX90 PHAT™ & AR44 Axle (2)
BRASBH3008	M3x8mm Round Head 12.9 Grade Nickel Plated Screws (10)	BRLC7004	Aluminum Low Profile Truss for BRX70/BRX80/BRX90 PHAT™ Axle Black
BRASBH3012	M3x12mm Round Head 12.9 Grade Nickel Plated Screws (10)	BRLC7005	Aluminum Link Mount for BRX70/BRX80/BRX90 PHAT™ Axle (2) Black
BRASBH3014	M3x14mm Round Head 12.9 Grade Nickel Plated Screws (10)	BRLC7010	Steel Leaf Spring Channel w/ Shock Mount for BRX70/BRX80/BRX90 PHAT™ Axle (2)
BRASBH3016	M3.0x16mm Round Head 12.9 Grade Nickel Plated Screws (4)	BRLC7014	Aluminum Middle Crossmember
BRASBH3018	M3.0x18mm Round Head 12.9 Grade Nickel Plated Screws (4)	BRLC7016	Aluminum Steering Servo Mount for CMS Setup
BRASBH3020	M3.0x20mm Round Head 12.9 Grade Nickel Plated Screws (2)	BRLC70201-B	Front output shaft for T-case OD
BRASBH3026	M3.0x26mm Round Head 12.9 Grade Nickel Plated Screws (2)	BRLC70202	AWB Front Crossmember
BRASCH2008	M2x8mm Socket Cap Screw 12.9 Grade Nickel Plated Screws (5)	BRLC70206	AWB Rear Crossmember
BRASCH2508	M2.5x8mm Socket Cap Screw 12.9 Grade Nickel Plated Screws (8)	BRLC70207	AWB Switch Leaver
BRASCH2510	M2.5x10mm Socket Cap Screw 12.9 Grade Nickel Plated Screws (4)	BRLC70210	Gear set 20Tx1 29Tx2 for T-case SWD & DIG
BRASCH3008	M3x8mm Socket Cap Screw 12.9 Grade Nickel Plated Screws (2)	BRLC70211	AWB Chassis Front Rail L/R
BRASEC30	E-Clip 3mm (2)	BRLC70212	AWB Chassis Rear Rail L/R
BRASFH2005	M2.5x5mm Counter Sunk Screw 12.9 Grade Nickel Plated Screws (4)	BRLC70214	AWB Chassis Side Bracket L/R
BRASFH2508	M2.5x8mm Counter Sunk Screw 12.9 Grade Nickel Plated Screws (10)	BRLC70215	AWB Slotted Plate (2)
BRASFH3006	M3x6mm Counter Sunk Screw 12.9 Grade Nickel Plated Screws (1)	BRLC70216	AWB Slotted Washer (4)
BRASFH3008	M3x8mm Counter Sunk Screw 12.9 Grade Nickel Plated Screws (10)	BRLC70218	AWB Front Offset Shock Tower L/R
BRASFH3010	M3x10mm Counter Sunk Screw 12.9 Grade Nickel Plated Screws (10)	BRLC70221	AWB Universal Receiver Box Set w/ Silicone Seals
BRASFH3018	M3x18mm Counter Sunk Screw 12.9 Grade Nickel Plated Screws (10)	BRLC70222	AWB ESC Plate
BRASNUTM3	M3 Nut nylon (5)	BRLC70223R	Mini Servo Mount for AWB
BRASNUTM4	M4 Nuts (4)	BRLC70225V2	Brass Bushing V2 for BRX70/BRX80/BRX90 PHAT Axle (4)
BRASPIN210	Hex Pin (Steel) 2x10mm (4)	BRLC70226	Kingpin for BRX70/BRX80/BRX90 PHAT Axle (4)
BRASSP471	Spacer D4x7x1 Stainless Steel (5)	BRLC70228	Stainless Steel Rear Upper Link (2)
BRASSPD470S	Spacer D4x7x0.5 (1)	BRLC70229	42mm Stainless Steel Rear Lower Link Spline Shaft (2)
BRASSPD5801	Spacer D5x8x0.1 (5)	BRLC70230	Stainless Steel Front Upper Link (1)
BRASSPD5805	Spacer D5x8x0.5 (9)	BRLC70231	Stainless Steel Front Lower Link (2)
BRASST3003	M3x3 SS Set Screw (4)	BRLC70232	Stainless Steel Rear Lower Link Barrel Left & Right
BRASST3022/DS	M3/2.2 x11 SS Steel Driveshaft Screw Pin (4)	BRLC70233	Stainless Steel Panhard Link
BRASST4004	M4x4 SS Steel Socket Set Screw (10)	BRLC7024	BRX70/BRX80/BRX90 PHAT™ Axle Housing with Black Diff Cover
BRASST4016	M4x16 SS Steel Socket Set Screw (10)	BRLC7025	BRX70/BRX80/BRX90 PHAT™ Axle Third Member Cover
BRBD8001	BADASS™ Ultra Hard Steel Axle Universal Driveshaft (2pcs) for BRX80 PHAT™ Axle BRD8022	BRLC7026	BRX70/BRX80/BRX90 PHAT™ Axle Black Diff Cover

PARTS LIST

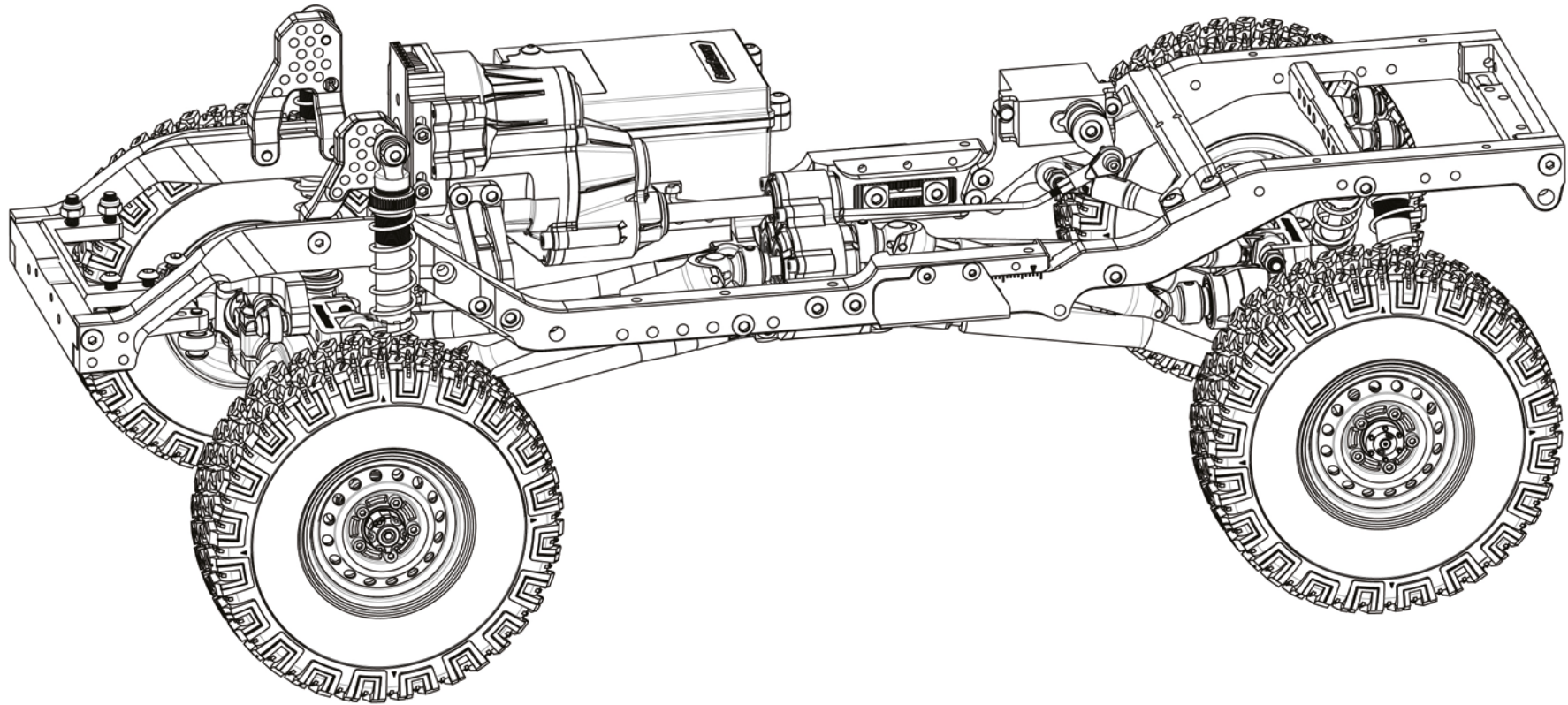
Part #	Description	Part #	Description
BRLC7026A	BRX70/BRX80/BRX90 PHAT™ Axle Housing	BRW780955RGM	1.55" 16-Hole Classic Steelie Reversible Beadlock Wheels (Rear) w/ XT504 Hubs (2)
BRLC7027V2	Steel Gearbox Adapter with Aluminum Motor Mount	BRX020020	High Clearance Center Alum Link Mount w/ Stainless Steel Plate
BRLC7029-12T	Spur gear 12T (1)	BRX020024	Axle Panhard Mount (1)
BRLC7029-15T	Spur gear 15T (1)	BRX020029	BCF2™ Gearbox Transmission w/ Bearing Holder Set
BRLC7029-20T	Spur gear 20T (2)	BRX020029A	Bearing Holder
BRLC7030	HD Steel Spur Gear Mount	BRX020110	Side Gearbox Mount Left & Right Black
BRLC7031	Internal Spur Gear 28T 32 Pitch	BRX020111	B2X™ Overdrive Ready Transfer Case Housing
BRLC7032	Motor spacer	BRX020115LKF	BRX80 Complete Front PHAT™ Axle Link Version Black
BRLC7039	30/8T Reverse HD Steel Triangular Keyed Bevel Helical Cut Diff Gear w/ Spool Set	BRX020115LKR	BRX80 Leaf Spring version Complete rear Axle
BRLC7040	3x6x5 mm Tapper Spacer(2)	BRXT504V2	ProBuild™ XT504 V2 5-Lug Aluminum 12mm Wheel Hub Adapters 4MM Offset Version 2 (2)
BRLC7041	3x6x3 mm Tapper Spacer(4)	JX/PDI-HV1151MG	JX Waterproof HV Mini Servo
BRLC7042	3x6x6 mm Tapper Spacer(2)		
BRLC7044B	Input shaft		
BRLC7044E	2-Speed Gear Unit (1)		
BRLC7045B	Shifter		
BRLC7045C	Stainless Steel Shift Rod		
BRLC7049	Aluminum 2 Speed Servo Horn Set		
BRLC7050	Stainless Steel Drag Link & Panhard Link Set w/ BADASS Rod Ends (2)		
BRLC7056	12mm Standard Aluminum Wheel Hex Adaptors (4)		
BRLC7059	Extension Cable (2)		
BRLC7064B	Aluminum Center Crossmember for BRLC7064 Leaf Spring		
BRLC7074A	Panhard Chassis Mount (1)		
BRLC7207-P	Guiding Shaft (1)		
BRLC7208	Rear output shaft for T-case OD & SWD		
BRLC7209	High Efficiency Coupling Shaft		
BRPG3212-3	32P 12T / 3.175mm Steel Pinion Gear		
BRQ90351	M2 Link Rod End Ball Joint (1)		
BRSH0070-SP	KUDU™ 70mm Coilover Scale Shock Absorbers (2)		
BRSH0080-SP	KUDU™ 80mm Coilover Scale Shock Absorbers (2)		
BRSHJR	Joint Retainers for KUDU™ Shocks (10)		
BRSHK030	30WT Shock Oil 15ml		
BRSORD6-15	D6x1.5 O-Ring (2)		
BRT10028	Tool Set		
BRT10037	Cable Wiring Retainer		
BRT10053	Pivot Ball Tool		
BRTR15504	1.55" MAXGRAPPLER Scale RC Tire Gekko Compound 3.74"x1.18" (95x30mm) Open Cell Foams (4)		
BRW750306A	Rod Ends M4 Nylon (Straight) 18.5mm (6)		
BRW750307D	M4 Nylon Rod Ends 20.0mm (Upwards) (2)		
BRW750310	Stainless Steel End Pivot Balls for KUDU™ Shocks (5)		
BRW780909/COVERF	Front Center Wheel Hub Cap For Boom Racing 1.55" / 1.9" Steelie Beadlock Wheels (XT5 Series)		
BRW780909/COVERR	Rear Center Wheel Hub Cap For Boom Racing 1.55" / 1.9" Steelie Beadlock Wheels (XT5 Series)		
BRW780955FGM	1.55" 16-Hole Classic Steelie Reversible Beadlock Wheels (Front) w/ XT504 Hubs Gun Meta		

PARTS LIST (Optional Accessories)

Part #	Description
Chassis Parts	
BRD9024	Brass Rear Knuckle Base Weights for BRX80 / BRX90 PHAT™ Axle (2)
BRLC70101-DIG	DIG Transfer Case Kit
BRLC70213	AWB Chassis Rear Rail XL (287-307mm) R/L
BRLC70219F	Tubular Alum Front Bumper
BRLC70219R	Tubular Alum Rear Bumper
BRLC70223A	Wire Cable Retainer for BRX01 AWB
BRLC70223L	Mini Servo Mount for BRX01 AWB
BRLC70301-SWD	SWD (Selective RWD/4WD) Transfer Case Kit
BRLC7086F	Front Skid Plate for BRX70/BRX80/BRX90 PHAT™ Axle
BRLC7086R	Rear Skid Plate for BRX70/BRX80/BRX90 PHAT™ Axle
BRLC7088	XT Diff Cover for BRX70/BRX80/BRX90 PHAT™ Axle
BRLC7089	Brass Front Knuckle Base Weights for BRX70/BRX80/BRX90 PHAT™ & AR44 Axle (2)
BRLC7092	Brass Small Weight Blocks 4g for BRX70/BRX80/BRX90 PHAT™ Axle Knuckle Weight Base (6)
BRLC7200	Servo Winch Mount Kit
BRLC7203	Aluminum Rear Shock Tower Damper Mount for BRX01 & BRX01 AWB (2)
BRLC70229-2XL	82mm Stainless Steel Rear Lower Link Spline Shaft (2)
BRLC70229-XL	62mm Stainless Steel Rear Lower Link Spline Shaft (2)
BRLC70235	AWB 2XL Billet Aluminum Rear Rails (7mm) 305-325MM / 12.0" to 12.8" L/R
BRLC70213	AWB XL Billet Aluminum Rear Rails (7mm) 285-305MM / 11.2" to 12.0" L/R
BRLC70234	AWB KUDU™ Front Skidplate with D-Ring Shackles
BRPT8022	Complete Front Assembled BRX80 Portal PHAT™ Axle
BRPT8023	Complete Rear Assembled BRX80 Portal PHAT™ Axle
BRLC70227	Servo Winch Mount Kit for BRX01 AWB & BRX01
BRKD003-116	KUDU™ Heavy-Duty 105.5–148.5mm Steel CVD Center Drive Shaft (1)
Gears	
BR955029	Overdrive HD Steel Keyed Bevel Helical Gear 27/8T + Diff Locker Spool Set
BR955040	Overdrive HD Steel Keyed Bevel Helical Gear 24/8T + Diff Locker Spool Set
BRLC70201-GEAR	Transfer Case Overdrive HD Steel Gear Set
Wheel Cap	
BRW780921GD	Scale 4WD Center Locking Hub Cap (2) Gold (XT5 Series)
BRW780921R	Scale 4WD Center Locking Hub Cap (2) Red (XT5 Series)
BRW780923	S100 Scale Center Wheel Hub Cap (2) Black (XT5 Series)
BRW780923PL	S100 Scale Center Wheel Hub Cap (2) Platinum (XT5 Series)
BRW780923S	S100 Scale Center Wheel Hub Cap (2) Silver (XT5 Series)
BRW780925BK	Spectre Scale Center Wheel Hub Cap (2) (XT5 Series) Black
BRW780925S	Spectre Scale Center Wheel Hub Cap (2) (XT5 Series) Silver
BRW780944	Retro Nylon Center Wheel Cap (4) (XT5 Series) w/ Tool
BRW780947	Dome Center Cap (2) Chrome (XT5 Series)

If you have questions, call Boom Racing at:
Email Boom Racing at sales@boomracing.com

WWW.ENJOYBEINGABADASS.COM

Part #	Description
Wheel Hub	
BRXT502PIN	XT502PIN 5-Lug Metal Wheel Pin Hub Adapters +2mm Positive Offset (2)
BRXT500V2	ProBuild™ XT500 V2 5-Lug Aluminum Wheel Pin Hub Adapters 0mm Offset V2 (2)
BRXT508V2	ProBuild™ XT508 V2 5-Lug Aluminum 12mm Wheel Hub Adapters 8mm Offset V2 (2)
BRXT512	ProBuild™ XT512 5-Lug Aluminum 12mm Wheel Hub Adapters 12mm Offset (2)
BRXT516V2	ProBuild™ XT516 V2 5-Lug Aluminum 12mm Wheel Hub Adapters 16mm Offset (2)
BRXT5DU	Adjustable Dually Adapter for 5-Lug Beadlock Wheel
LED	
BRTL8007	KUDU™ LED Light Module System for BRX01 AWB ZIL Pickup
Rock Monster	
BRRM15504	Rock Monster GREEN Silicone Tire Insert 3.38x0.91" for 1.55" Baby Hustler / MAXGRAPPLER Tires (2)
Springs	
BRKSPRING-45 Set	KUDU™ Shock Springs 45mm Set (Super Hard, Hard, Medium, Soft, Super Soft) (10)
BRKSPRING-55 Set	KUDU™ Shock Springs 55mm Set (Super Hard, Hard, Medium, Soft, Super Soft) (10)
Pinion Gear	
BRPG3209-3	32P 9T / 3.175mm Steel Pinion Gear (1)
BRPG3210-3	32P 10T / 3.175mm Steel Pinion Gear (1)
BRPG3211-3	32P 11T / 3.175mm Steel Pinion Gear (1)
BRPG3213-3	32P 13T / 3.175mm Steel Pinion Gear (1)
BRPG3214-3	32P 14T / 3.175mm Steel Pinion Gear (1)
BRPG3215-3	32P 15T / 3.175mm Steel Pinion Gear (1)
BRPG3216-3	32P 16T / 3.175mm Steel Pinion Gear (1)
BRPG32COMBO1-3	32P Steel Pinion Gear Combo 9T-12T (4)
BRPG32COMBO2-3	32P Steel Pinion Gear Combo 13T-16T (4)
Shock Oil	
BRSHK010	BADASS™ Silicone Shock Oil 10wt 60ml
BRSHK015	BADASS™ Silicone Shock Oil 15wt 60ml
BRSHK020	BADASS™ Silicone Shock Oil 20wt 60ml
BRSHK025	BADASS™ Silicone Shock Oil 25wt 60ml
BRSHK030	BADASS™ Silicone Shock Oil 30wt 60ml
BRSHK035	BADASS™ Silicone Shock Oil 35wt 60ml
BRSHK040	BADASS™ Silicone Shock Oil 40wt 60ml
BRSHK045	BADASS™ Silicone Shock Oil 45wt 60ml
BRSHK050	BADASS™ Silicone Shock Oil 50wt 60ml
BRSHK055	BADASS™ Silicone Shock Oil 55wt 60ml
BRSHK060	BADASS™ Silicone Shock Oil 60wt 60ml
BRSHK065	BADASS™ Silicone Shock Oil 65wt 60ml
BRSHK070	BADASS™ Silicone Shock Oil 70wt 60ml
BRSHK075	BADASS™ Silicone Shock Oil 75wt 60ml
BRSHK080	BADASS™ Silicone Shock Oil 80wt 60ml

NOTES

Adam Sajdak (Germany)

The BRX01 AWB is a very successful chassis design that works great off-road! At the same time, thanks to the adjustable wheelbase (AWB), it gives us unlimited possibilities in the future, allowing us to adapt the frame to individual projects. It looks like a great multiplatform that will work in any project.



Jeremy Kilburn (United States)

Another unmatched build experience from Boom Racing! The quality and thoughtfulness of the AWB kit presents unlimited possibilities with builders, competitors and newcomers in mind.

Shawn Roche (United States)

I have tested all the BRX trucks and I was excited to get involved with the AWB because it is the chassis the industry has needed for a very long time. Based on the tried a true BRX01 drivetrain it is reliable and it out performs any stock leaf truck I have ever run, this is the perfect chassis for a builder or anyone looking for something different and still want insane performance. Excellent job Boom Racing.



Andreas Hahn, Stefan Dölderer (Austria)

Thank you for the opportunity to test this model in detail. First of all, the quality is, as always, very high and building the AWB model is fun. Thanks to the adjustable chassis, you will have many options for driving different bodies in the future. The quality of the adjustment mechanism is very good. The rest is tried and tested BRX01 technology which, as everyone knows, is perfect.

Matthew Maynard (United States)

My journey with Boom Racing began with the pre-order of the BRX02 carbon fiber chassis kit. From the moment I held it, I knew this was an amazing company. Over the years, as I built more trucks, my trust in their quality and professionalism only grew, both in their rigs and customer service. Now, I have the honor of standing in a Boom tent, talking tiny trucks, and helping bring exciting new kits to the RC market. Whether at events or online, I'm proud to be part of this incredible community. Congrats - if you're reading this, you're now part of the Boom family. Welcome, and enjoy committing badassery!



Peter Gray (United Kingdom)

Building and then running the BRX01 AWB has been an eye opener. It's made me realise why I love this aspect of the hobby so much. A photorealistic body combined with a chassis, transmission and tyre choice that punches well above its wheelbase and wheel size. Add to that the game changing adjustability of the wheelbase via the AWB Chassis and you have a rig that I'm convinced will inspire many a custom build globally... (hell, I'm already planning something myself!)

Darius Cybula (Germany)

Chassis of new possibilities. The ability to adjust the wheelbase to individual needs gives freedom of choice of bodywork, and the ease with which it can be done even encourages it. All this combined with proven solutions, already known in the BRX01 chassis. I am convinced that it will soon become the most frequently purchased chassis among hobbyists of both scale and performance cars.





BOOMRACING[®]
Your Radio Control Car Specialist

BRX01

AWB

**ADJUSTABLE WHEELBASE 1/10
4WD RADIO CONTROL CHASSIS KIT**

WWW.ENJOYBEINGABADASS.COM